

C

N

H

S



COURSE  
CATALOG

2017-2018

# COLUMBUS NORTH HIGH SCHOOL

COURSE CATALOG: 2017-2018

This Course Catalog contains as much information as possible about the courses being offered for next year, the various graduation requirements, and any other pertinent information. It is intended as a planning tool that can assist students as they set goals and make informed plans for the future. CNHS is dedicated to providing a quality educational experience through high expectations and we are devoted to the success of all students. **Please be aware that information in this catalog is subject to change at any time!**

Columbus North High School is committed to equal opportunity and does not discriminate on the basis of race, color, national origin, sex (including transgender status, sexual orientation and gender identity), disability, age, religion, military status, ancestry, or national origin including limited English proficiency, in any educational opportunity. No person is excluded from participation in, denied the benefits of, or otherwise subjected to unlawful discrimination on such basis under any educational program or student activity.

<p><b>IMPORTANT CONTACTS:</b></p> <p>For up-to-date information, visit: <a href="http://www.bccsc.k12.in.us/northhs">www.bccsc.k12.in.us/northhs</a> and <a href="http://www.cnhsmedia.com">www.cnhsmedia.com</a></p> <p><b>Main Office</b> <b>812-376-4431 or 812-376-4432</b> The Main Office coordinates personnel and services, implementing laws, policies and practices to support students, faculty and staff.</p> <p><b>Counseling Center</b> <b>812-376-4292 or 812-376-4292</b> The Counseling Center focuses on the academic, career, personal and social development of students.</p> <p><b>Dean's Office</b> <b>812-376-4251 or 812-376-4241</b> The Dean's Office focuses on discipline, behavior, attendance of students, and overall school safety.</p> <p><b>Nurse's Office</b> <b>812-376-4262</b> The Nurse's Office focuses on health and care of students.</p> <p><b>Special Education Office</b> <b>812-376-4205</b> The Special Education Department works with students and their families, who have been identified with special needs.</p> <p><b>English Language Learners- ELL</b> <b>812-343-8465</b> The ELL Parent Engagement Interpreter will assist families where language may be a barrier within the school.</p>	<p><b>OTHER IMPORTANT CONTACTS</b></p> <table border="0"> <tr><td>Athletic Office</td><td>812-376-4265</td></tr> <tr><td>Band</td><td>812-376-4258</td></tr> <tr><td>Bookstore</td><td>812-376-4294</td></tr> <tr><td>Business Ed</td><td>812-376-4264</td></tr> <tr><td>C4 Office</td><td>812-376-4240</td></tr> <tr><td>Cafeteria</td><td>812-376-4263</td></tr> <tr><td>Child Educare</td><td>812-376-4362</td></tr> <tr><td>Choral Dept.</td><td>812-376-4548</td></tr> <tr><td>English</td><td>812-376-4253</td></tr> <tr><td>Health/PHys Ed</td><td>812-376-4259</td></tr> <tr><td>Library</td><td>812-376-4254</td></tr> <tr><td>Mathematics</td><td>812-376-4206</td></tr> <tr><td>Student Media</td><td>812-376-4260</td></tr> <tr><td>Science</td><td>812-376-4261</td></tr> <tr><td>Social Studies</td><td>812-376-4237</td></tr> <tr><td>Theater</td><td>812-376-4236</td></tr> <tr><td>Transportation</td><td>812-376-4246</td></tr> <tr><td>Grad Records</td><td>812-376-4463</td></tr> <tr><td>World Language</td><td>812-376-4435</td></tr> </table>	Athletic Office	812-376-4265	Band	812-376-4258	Bookstore	812-376-4294	Business Ed	812-376-4264	C4 Office	812-376-4240	Cafeteria	812-376-4263	Child Educare	812-376-4362	Choral Dept.	812-376-4548	English	812-376-4253	Health/PHys Ed	812-376-4259	Library	812-376-4254	Mathematics	812-376-4206	Student Media	812-376-4260	Science	812-376-4261	Social Studies	812-376-4237	Theater	812-376-4236	Transportation	812-376-4246	Grad Records	812-376-4463	World Language	812-376-4435	<table border="0"> <thead> <tr> <th><b>CONTENTS</b></th> <th><b>Page</b></th> </tr> </thead> <tbody> <tr><td>General Information</td><td>2</td></tr> <tr><td>Athletic Eligibility</td><td>3</td></tr> <tr><td>Core 40 Diploma</td><td>4</td></tr> <tr><td>Educational Pathways</td><td>6</td></tr> <tr><td>English</td><td>8</td></tr> <tr><td>Mathematics</td><td>11</td></tr> <tr><td>Science</td><td>15</td></tr> <tr><td>Social Studies</td><td>18</td></tr> <tr><td>Health/PE</td><td>20</td></tr> <tr><td>World Language</td><td>22</td></tr> <tr><td>Journalism</td><td>25</td></tr> <tr><td>Visual Arts</td><td>26</td></tr> <tr><td>Instrumental Music</td><td>29</td></tr> <tr><td>Vocal Music</td><td>30</td></tr> <tr><td>Business</td><td>31</td></tr> <tr><td>C4</td><td>33</td></tr> <tr><td>Special Education</td><td>46</td></tr> </tbody> </table>	<b>CONTENTS</b>	<b>Page</b>	General Information	2	Athletic Eligibility	3	Core 40 Diploma	4	Educational Pathways	6	English	8	Mathematics	11	Science	15	Social Studies	18	Health/PE	20	World Language	22	Journalism	25	Visual Arts	26	Instrumental Music	29	Vocal Music	30	Business	31	C4	33	Special Education	46
Athletic Office	812-376-4265																																																																											
Band	812-376-4258																																																																											
Bookstore	812-376-4294																																																																											
Business Ed	812-376-4264																																																																											
C4 Office	812-376-4240																																																																											
Cafeteria	812-376-4263																																																																											
Child Educare	812-376-4362																																																																											
Choral Dept.	812-376-4548																																																																											
English	812-376-4253																																																																											
Health/PHys Ed	812-376-4259																																																																											
Library	812-376-4254																																																																											
Mathematics	812-376-4206																																																																											
Student Media	812-376-4260																																																																											
Science	812-376-4261																																																																											
Social Studies	812-376-4237																																																																											
Theater	812-376-4236																																																																											
Transportation	812-376-4246																																																																											
Grad Records	812-376-4463																																																																											
World Language	812-376-4435																																																																											
<b>CONTENTS</b>	<b>Page</b>																																																																											
General Information	2																																																																											
Athletic Eligibility	3																																																																											
Core 40 Diploma	4																																																																											
Educational Pathways	6																																																																											
English	8																																																																											
Mathematics	11																																																																											
Science	15																																																																											
Social Studies	18																																																																											
Health/PE	20																																																																											
World Language	22																																																																											
Journalism	25																																																																											
Visual Arts	26																																																																											
Instrumental Music	29																																																																											
Vocal Music	30																																																																											
Business	31																																																																											
C4	33																																																																											
Special Education	46																																																																											
	<p><b>Email Addresses</b></p> <p>Most CNHS staff members can be contacted by email. The address is usually the person's last name and first initial, followed by @bccsc.k12.in.us. Example: jonesb@bccsc.k12.in.us. You can also email teachers via Parent Portal.</p> <p><b>Parent Portal in PowerSchool</b></p> <p>Through this website parents can see their student's grades and attendance. Parents can easily e-mail teachers. Go to the main office of your child's school to get login information. Parent Portal access: <a href="https://powerschool.bccsc.k12.in.us">https://powerschool.bccsc.k12.in.us</a></p>																																																																											

## Stay Connected to the CNHS Counseling Center!



@cnhscounselingcenter



@CNHSCounselingCenter



@cnhscounseling



Receive updates via text or email!

Send the following text to **81010**

**Class**      **Text**

Class of 2018: @cnhs2018

Class of 2019: @cnhs2019

Class of 2020: @cnhs2020

Class of 2021: @cnhs2021



# GENERAL INFORMATION

## HOW ARE STUDENTS SCHEDULED?

There will be grade level class meetings in which counselors will present curriculum and details for the next year. Later, counselors will meet with students individually to go over course selections and students will input their course selections online at that time.

Students will plan their schedule for the entire following year. During the course selection time, students should plan a course load that will best prepare them to meet graduation requirements and post high school plans. Students should select courses appropriate to their diploma goal, career goal, and academic abilities. Recommendations from the students' current teachers will be very helpful in making the appropriate course selections.

The course selection process encompasses several weeks to allow for thoughtful, informed decision making. After all schedules are collected from students, the program of courses to be offered in the coming year is finalized, teachers are hired and assigned to courses, and books/materials are ordered.

## SCHEDULE CONFLICTS AND CHANGES

On occasion, a course will not be available to a student based on a variety of reasons: i.e. a course conflict, not enough enrollment for there to be a class, or the class is overloaded. It is imperative that alternative courses have been placed where requested on Course Selection Sheets.

No schedule changes will be permitted unless one of the following situations exists: the student has been misplaced, a scheduling error has occurred, a change is needed to ensure timely graduation, or other extenuating circumstance exists. Requests for schedule changes will be accepted during the first 3 days of the semester.

## RETKING A COURSE

A course can be retaken due to receiving a grade of "C+" or below. When repeated, the higher of the two grades will be included in the grade point average and credits attempted.

## COURSE INFORMATION AND FEES

Every attempt has been made to include an accurate and clearly defined description of each course offered at Columbus North High School in this Course Catalog. However, the fees that are listed are based on the prior school year. The actual course fees will be determined next summer. Thus, the fee for some courses may be considerably different from what is listed.

## INCOMING FRESHMEN

The transition from middle school to high school can be both very exciting and sometimes scary for both the students and their parents. Middle school teachers and counselors have worked hard at informing students about information such as credits, graduation requirements, and diploma requirements.

North counselors will visit each middle school and present all the necessary information and materials for 8th graders and their families to make choices about what courses should be taken next year.

There will also be an Eighth Grade Family Night in the evening at North for families to not only acquire general information, but also have time to ask questions of each academic department.

Freshman Orientation is intended to serve as an introduction to Columbus North High School for all incoming freshmen and their parents. It is held a few days before school begins. Students are invited by mail to come to North to get their schedule, locker number and combination, a tour of the building, and more information about various school policies and ways to get involved in high school activities. Parents are invited to meet with the principal for a question and answer session while students explore the building. Upperclassmen are available to answer questions and give directions.

## GRADE POINT AVERAGE AND CLASS RANK

At the end of each semester, each student is ranked according to the 12.0 grade point average. Grade points are assigned for each grade according to the following scale:

Letter	12 Point	4 Point
A+	12	4.33
A	11	4.00
A-	10	3.67
B+	9	3.33
B	8	3.00
B-	7	2.67
C+	6	2.33
C	5	2.00
C-	4	1.67
D+	3	1.30
D	2	1.00
D-	1	0.67
P* (passing)	1	0.67
F (failure)	0	0.00

\* A grade of "P" does not count towards a required class for a diploma.

The grade point average is determined by dividing the total number of points earned by the credits attempted. GPA and Class Rank are figured at the end of each semester. For the purpose of determining certain scholarship recipients, valedictorian, salutatorian, etc., the 7th semester 12.0 grade point average and the length of the student's attendance at North are taken into consideration. The official ranking of the graduating class is done at the close of the eighth semester.

## HONOR ROLL

The Honor Roll is compiled after each grading period. Students earning a grade point average of "B+" (9.0) and above with no grade below "C-" are designated as honor roll students. Students with incompletes will not be included on the honor roll.

## HIGH SCHOOL GRADUATION EXAMS

The purpose of the Indiana Statewide Testing for Educational Progress Plus (ISTEP+) program is to measure student achievement in the subject areas of English/ Language Arts, and Mathematics. In particular, ISTEP+ reports student achievement levels according to the Indiana Academic Standards.

The ISTEP+ End-of- Course Assessments (ECAs) are criterion-referenced assessments developed specifically for students completing their instruction in Algebra I, and English 10. The class of 2018 is the last class of students to take the ECAs.

ISTEP+ starts with the class of 2019. In 10th grade all students take the ISTEP+ and are tested over Math and English.

## THE SENIOR PROJECT

Details at: [www.bcsc.k12.in.us/northhs](http://www.bcsc.k12.in.us/northhs) - click on "Senior Project"

The Senior Project at CNHS is a graduation requirement for all students. Students will develop their projects based on their personal interests and their abilities to demonstrate the BCSC Expert Learner Outcomes. By focusing on the identification of these points throughout the proposal, planning, implementation, and reflection portions of the Senior Project, students will gain an understanding of the relevance of their studies here at North and their connections with the community. It is our hope that students will grow through this process. Students are encouraged to identify projects that match passions or interests, demonstrate the BCSC Expert Learner Outcomes, and connect to the community.

The Five Required Components:

1. **Proposal:** A plan that identifies and outlines the intentions of the project. Specifics as to how the project benefits both the student and the community are clearly stated.
2. **Paper:** Research to provide additional background information for the project. Proper research techniques are embedded in the Senior English curriculum.
3. **Project:** Collaboration with community members in a responsible, organized manner in order to facilitate the development and implementation of the proposed project.
4. **E-portfolio:** Every aspect of the project will be documented and presented chronologically in e-portfolio format.
5. **Presentation:** E-portfolios and projects will be presented in front of a panel of teachers and community members for evaluation.

Students will be supported in all components of the Senior Project as part of their high school curriculum. The skills necessary to complete the project will be taught in courses throughout the student's high school experience. It is the student's responsibility to apply the skills learned in the classroom to the planning and development of each Senior Project. All students will select a Community Mentor to help them with their project.

## EARLY GRADUATION

It is advisable for students to complete eight semesters of high school. Graduation may be achieved after seven semesters if all forty required credits have been completed. This must be planned when classes are being selected for the student's senior year. A form requesting seven semester graduation must be filed with the student's counselor. This form must be signed by both student and parent in the spring of the junior year. The principal will have the final determination. A mid-year graduate may participate in end-of-the-year school activities. Participation in graduation exercises requires attendance at the scheduled graduation practice. Under special circumstances, six semester graduation is possible. The student and parents are to contact the student's school counselor, preferably as early as their freshman year.

# ATHLETIC ELIGIBILITY

## HIGH SCHOOL ATHLETIC ELIGIBILITY

Students must be passing 6 classes in both the preceding and current quarters to be eligible for interscholastic athletics. Grades are evaluated on a 9-week grading period basis. Also, a current athletic physical must be on file in the Athletic Office.

## COLLEGE ATHLETIC ELIGIBILITY

A high school student must be academically strong to be eligible to participate in athletics at the college level. Students may contact the Athletic Department for specific eligibility requirements. It is the student's responsibility to make sure he/she is eligible to play sports in college.

\*Note: NCAA will not accept all online courses.

For complete NCAA Clearinghouse information, visit: [www.eligibilitycenter.org](http://www.eligibilitycenter.org).

For complete NAIA information visit: [www.naia.org](http://www.naia.org).

## Course and Credit Requirements

<b>English/ Language Arts</b>	<b>8 credits</b> English 9, English 10, English 11, English 12
<b>Mathematics</b>	<b>6 credits (in grades 9-12)</b> 2 credits: Algebra I 2 credits: Geometry 2 credits: Algebra II <small>Students must take a math or quantitative reasoning course each year in high school.</small>
<b>Science</b>	<b>6 credits</b> 2 credits: Biology I 2 credits: Chemistry I or Physics I or Integrated Chemistry/Physics (ICP) 2 credits: any Core 40 science course
<b>Social Studies</b>	<b>6 credits</b> 2 credits: World History/Civilization or Geography/History of the World 2 credits: U.S. History 1 credit: U.S. Government 1 credit: Economics
<b>Directed Electives</b>	<b>5 credits</b> Includes one or more of the following areas: Career and Technical Education (C4), Fine Arts, Business, Journalism, or World Languages
<b>Physical Education</b>	<b>2 credits</b> PE Team and PE Individual
<b>Additional Requirement</b>	<b>1 credit</b> Preparing for College and Careers
<b>Health and Wellness</b>	<b>1 credit</b>
<b>Electives</b>	<b>5 credits</b>
<b>40 Total State Credits Required</b>	
<b>Additional CNHS Graduation Requirements</b>	
<ul style="list-style-type: none"> <li>• Pass ISTEP Assessment in math, English, and science</li> <li>• Complete all components of the Senior Project</li> </ul>	

**CORE40** with Academic Honors **47 Credits Required**

For the Core 40 with Academic Honors diploma, students must:

- Complete all requirements for Core 40.
- Earn 2 additional math credits above Algebra 2.
- Earn 6-8 world language credits (6 credits in one language or 4 credits each in two languages).
- Earn 2 fine arts credits.
- Earn a grade of a "C-" or better in courses that will count toward the diploma.
- Have a grade point average of a "B" or better.
- Complete one of the following:
  - A. Complete 2 or more AP courses and take corresponding AP exams
  - B. Earn 6 transcribed college credits in dual credit courses from the approved dual credit list.
  - C. Earn two of the following:
    1. A minimum of 3 transcribed college credits from the approved dual credit list,
    2. 2 credits in AP courses and corresponding AP exams.
  - D. Earn a combined score of 1750 or higher on the SAT critical reading, mathematics and writing sections and a minimum score of 530 on each
  - E. Earn an ACT composite score of 26 or higher and complete written section

**CORE40** with Technical Honors **47 Credits Required**

For the Core 40 with Technical Honors diploma, students must:

- Complete all requirements for Core 40.
- Earn 6 credits in the college and career (C4) courses in a state-approved College & Career Pathway and one of the following:
  1. State approved, industry recognized certification or credential, or
  2. Pathway dual credits from the approved dual credit list resulting in 6 transcribed college credits
- Earn a grade of "C-" or better in courses that will count toward the diploma.
- Have a grade point average of a "B" or better.
- Complete one of the following:
  - A. Any one of the options (A - F) of the Core 40 with Academic Honors
  - B. Earn the following scores or higher on WorkKeys: Reading for Information – Level 6, Applied Mathematics – Level 6, and Locating Information–Level 5.
  - C. Earn the following minimum score(s) on Accuplacer: Writing 80, Reading 90, Math 75.
  - D. Earn the following minimum score(s) on Compass: Algebra 66, Writing 70, Reading 80.

# CORE 40 DIPLOMA

The Core 40 Diploma will be referred to as "Core 40" throughout the Course Catalog. Students must meet the Core 40 requirements to be considered for admission to an Indiana four-year college or university. Therefore, all college-bound students are advised to select from the following as a minimum preparation for college. In addition to these requirements, many four-year colleges require students have two years of World Language. Refer to the college's website for specific admission requirements.

## Diploma Checklist

<b>CORE 40 Diploma Requirements</b>			
English (8 credits)		Social Studies (6 credits)	
	English 9-1		W. Hist/Geog 1
	English 9-2		W. Hist/Geog 2
	English 10-1		US History 1
	English 10-2		US History 2
	English 11-1		Government
	English 11-2		Economics
	English 12-1	<b>HPER (3 credits)</b>	
	English 12-2		PE Team
<b>Math (6 credits)</b>			PE Individual
	Algebra 1-1		Health
	Algebra 1-2	<b>Science (6 credits)</b>	
	Geometry 1		Biology 1
	Geometry 2		Biology 2
	Algebra 2-1		Chem/Phys/ICP 1
	Algebra 2-2		Chem/Phys/ICP 2
<b>BCSC Requirement</b>			1 other science
	Prep. College & Careers		2 other science
<b>Other Requirements</b>			
	40 credits		
	10 <sup>th</sup> Grade ISTEP		
	Senior Project		
	Earn 6 math credits while in high school		
	Take math or quantitative reasoning every year in high school		

<b>Academic Honors</b>		<b>Technical Honors</b>	
World Language		Technical Sequence	
	1 <sup>st</sup>		<b>PATHWAY:</b>
	2 <sup>nd</sup>		1 <sup>st</sup>
	3 <sup>rd</sup>		2 <sup>nd</sup>
	4 <sup>th</sup>		3 <sup>rd</sup>
	5 <sup>th</sup>		4 <sup>th</sup>
	6 <sup>th</sup>		5 <sup>th</sup>
	7 <sup>th</sup>		6 <sup>th</sup>
	8 <sup>th</sup>	<b>Other</b>	
<b>Fine Arts</b>			47 credits
	1 <sup>st</sup> Sem		7.0 GPA
	2 <sup>nd</sup> Sem		No required course under C-
<b>Other</b>		<b>Option 1 or 2</b>	
	47 credits		1: Approved Certification
	7.0 GPA		2: Dual Credit (6)
	No required course under C-	<b>Complete ONE of the following</b>	
<b>One Option Below</b>			Option A-E with Academic Honors
	A: 2 AP & tests		Work Keys Scores
	B: 6 dual credits		Accuplacer Scores
	C: 1 AP AND 3 dual credit		Compass Scores
	D: SAT score		
	E: ACT score		

# EDUCATIONAL PATHWAYS

A variety of opportunities are available to Columbus North High School students that will increase the scope and sequence of a student's high school curriculum, prepare students with both knowledge and skills for post-high school, and can even earn college credit. In addition to the diploma requirements set forth by the State of Indiana & BCSC (Core 40, Core 40 with Technical Honors, and Core 40 with Academic Honors), students in BCSC may earn certification in a variety of pathways. Students can choose more than one Pathway. They are not exclusive!

## ADVANCED PLACEMENT PATHWAY

Advanced Placement (AP) courses provide in-depth study in a number of subjects and preparation for national exams administered by the College Board given in May. These exams are scored on a scale of 1 to 5 with 5 being the highest score. Students who perform well on the AP exam may receive college credit and/or advanced placement in their college course work. Each college determines its own Advanced Placement policy and will specify the score on each exam necessary for credit of advanced standing. Earning 4 or more AP credits and taking the corresponding exams will satisfy a requirement for earning a Core 40 with Academic Honors Diploma. Students are expected to take the AP Exam at the end of the course. The exams contain either an essay or problem-solving section and another section consisting of multiple-choice questions. Exams are given at CNHS in May. The exam fee is \$93.00 and the State of Indiana has paid for Math and Science exams in the past. Please check with your school counselor if funding assistance is necessary.

## DUAL CREDIT AND EARLY COLLEGE PATHWAY

Students have a variety of ways to earn college credits while they are still in high school. The terms dual credit, early college, and doubling up all mean about the same thing. The following are brief explanations:

**Dual Credit** - Some high school classes offered at CNHS earn both high school credit and college hours - North has many of these classes and they are identified in the Course Catalog. Students will need to complete an application for the credit. In most cases, a student is required to have a certain PSAT, SAT, or ACT score, or must take and pass an exam given by the college to qualify for the credit. In many cases, the student must earn a minimum grade in the class. Dual Credit opportunities are revised on an annual basis by institutions of higher learning. Therefore, course offerings for dual credit may change from year to year.

**Early College** - Students may choose to take a college class offered on a college campus while earning both college and high school credits - In Columbus, both Ivy Tech and IUPUC offer Early College Programs. A student needs to set up an appointment at the college to investigate course possibilities and class time. Students must make sure the college course(s) selected matches with a high school course offering. The student will then complete an Early College application and follow instructions for the placement tests. A student is required to have a certain score on the PSAT, SAT, ACT, or an exam given by the college to qualify for the credit. Prior to the beginning of the course, the student will submit the completed documentation of registration in the Early College Course to their high school counselor. The CNHS schedule will be adjusted to accommodate the college course. If the student desires to have the college grade on their high school transcript, they will need to submit verification of grades to the CNHS counseling center within two weeks of completion of the college class. (Karmen, don't they need to make sure that there is a high school equivalent available?)

**Advanced Placement (AP)** - Some colleges give credits for certain classes if a student achieves a certain score on the AP Exam.

**Advanced College Project** - These are Indiana University courses taught during the school day here at Columbus North High School. ACP Courses at North are currently AP Calculus, Chemistry 2, AP Physics, German 3 and 4, English W131 and English L202. Students can earn both high school and college credit. Cost for the class is determined by Indiana University.

Caution: Contact both the university and the department you are interested in to be assured the credit will transfer.

## GLOBAL STUDIES PATHWAY

The Global Studies Pathway will be referred to as GS throughout the Course Catalog.

The purpose of this pathway is to engage students in global issues and to prepare them to live and work productively in an increasingly interconnected and interdependent world. The Global Studies Pathway is interdisciplinary and cross-cultural in design. Pedagogically, the instruction will focus on problem-based instruction, Socratic methods, and collaboration. Students will have opportunities to conduct research on educational themes that explore international issues and challenges to our world today. This pathway will appeal to students who have an awareness of the ever changing world, desire to be productive citizens in a global world, and are able to see the world in a "big picture" framework. In addition to the diploma requirements set forth by the State of Indiana & BCSC (Core 40, Core 40 with Technical Honors, and Core 40 with Academic Honors), students in BCSC may earn certification in a variety of pathways.

**To earn certification in Global Studies:** Students must complete all of the core course requirements set forth by their desired diploma and complete the following courses to be counted toward the elective & directed elective credits:

1. *If you are earning a Core 40 or Technical Honors Diploma:*

Must complete: 6 credits (any combination) in World Languages, Sociology, Psychology, Art Appreciation.

*If you are earning an Academic Honors Diploma:*

Must complete: 6 credits of World Language in one language or 8 credits in two or more languages and Art Appreciation (as 1 of the 2 required Fine Arts credits for this diploma), Sociology, Psychology.

AND



## 2. ALL Diplomas:

Must select 4 credits from the following courses (a maximum of 2 credits can be used in each Band, Choir, and/or Journalism): AP European History, AP Computer Programming, Earth/Space Science, Geography & History of the World, Humanities, Interpersonal Relations, Introduction to Communications, Natural Resource, Statistics, AP Statistics, World History & Civilization, Global Economics, Advanced Business College Credit, Principles of Marketing, AP Environmental Science, AP Psychology, any Journalism, any Choir, or any Band.

## C4 COLUMBUS AREA CAREER CONNECTION PATHWAY

C4 Columbus Area Career Connection prepares students for career exploration, post-secondary studies and immediate employment. In C4 classes, students can begin preparing for the career they know they want or explore a variety of careers they may want to “try on” to see if they are truly interested. Some of the many benefits of taking a C4 class are:

- Over 125 course offerings in a variety of career areas
- FREE or greatly reduced college dual credit while taking their C4 classes
- Dual Credit counts toward both the Academic and Technical Honors diplomas
- Career pathway documents assist with post-secondary transition
- Curriculum is project-based
- Curriculum is aligned with state academic standards
- Hands-on activities make learning relevant
- School-to-Work and advanced job placement opportunities are available
- National and/or state certification opportunities
- Professional youth organizations to develop leadership and communication skills
- C4 students graduate at a higher rate than non-C4 students
- C4 students enroll in postsecondary education in greater numbers than non-C4 students
- C4 students earn more money than non-C4 students who enter the workforce

## MCDOWELL ALTERNATIVE PATHWAY

The mission of McDowell Alternative High School is to provide a supportive learning environment for a student seeking an alternative pathway to pursue his/her education. Students set academic, behavior and self-management goals with a focus on transitioning into postsecondary education, training, or work. The program is designed for students who are disengaged or disconnected from school. Students apply for McDowell through their counselor at North. Once the process is completed, the student will become part of a prioritized wait list for an opening at one of the quarter breaks. North and McDowell staff collaborate to determine if the student and McDowell are a good fit. The McDowell counselor will meet with the student and parent to develop the Student Success Plan. Once admitted, the student may take up to three academic classes each nine weeks. Students are encouraged to continue with electives and/or other courses needed at North or through C4. Students will have the option to return to North at the end of each semester.

## ONLINE COURSES

There are online course options available for students who: 1) failed and must retake a class, 2) received a C+ or lower in a class and wish to retake the class (at the same level) for a higher grade, 3) cannot fit all desired classes into their 4 year course plan and choose to supplement coursework with online classes. The fees for online classes vary. Please see your counselor if you are interested in this option.

Note: NCAA: will not accept all online classes.

## COLUMBUS SIGNATURE ACADEMY - NEW TECH PATHWAY

CSA is a magnet school that draws students from North and East. Students who elect to attend CSA enter a stratified lottery that replicates the demographic of the two high schools. Columbus Signature Academy New Tech is the 9th-12th grade campus of a K-12th program (students in the 8th grade CSA Team are automatically eligible to enroll in the 9th grade CSA New Tech Class). The instructional framework integrates many core classes, and includes STEM focus (Science, Technology, Engineering and Math) within a wall-to-wall project based learning environment. Freshmen take Global Science Perspectives (English 9 and Environmental Studies). Juniors take American Heritage (English 11 and US History). Geometry is integrated with PLTW: Introduction to Engineering Design. Students work in a one-to-one wireless environment. All students earn a Core 40 or Core 40 with Academic or Technical Honors Diploma. CSA students are eligible to participate in athletics, band, and other extracurricular activities through their home school of either East or North. They may also choose to attend one of the two larger high schools, two periods a day for electives not offered on the CSA campus.





# ENGLISH

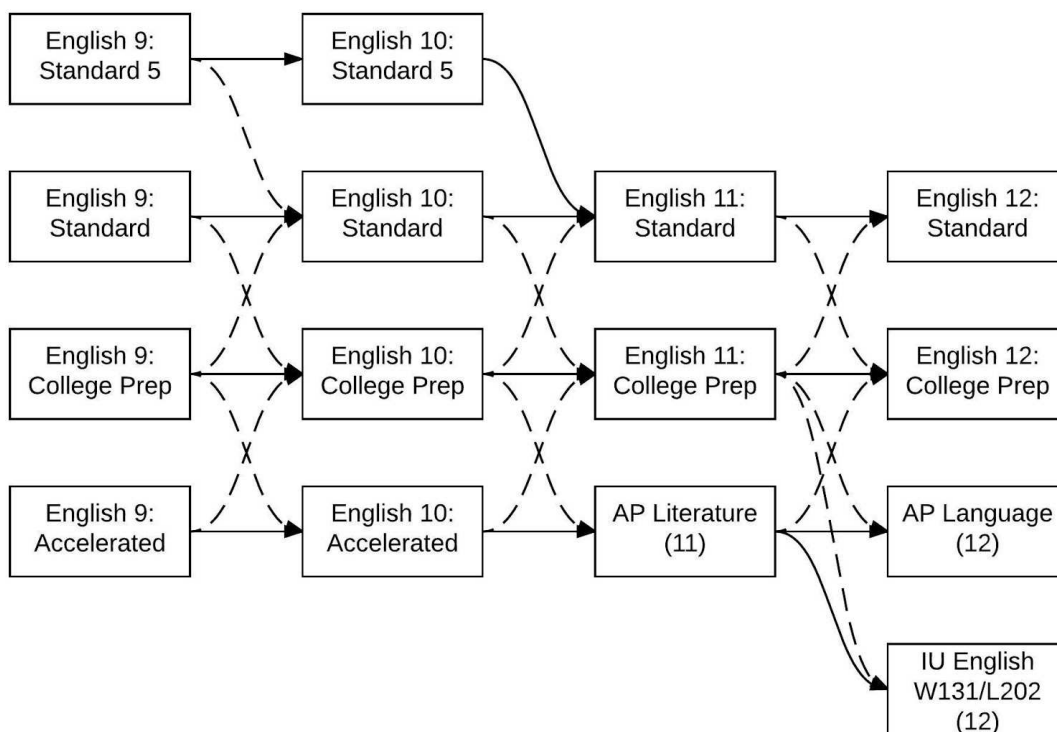

## FRESHMAN CURRICULUM DESCRIPTION

The freshman year includes a study of various literary genres: short stories, poems, novellas, plays and novels. Composition instruction includes work with thesis statements, introductions, conclusions, specific support and transitions. Freshmen students study grammar to learn how to use correct structure in writing. All classes meet the state standards and study much of the same literature. Accelerated classes cover more material, move at a faster pace and go into greater depth of study than English 9 (college prep). Standard classes focus more directly on basic skills related to future end of course assessments.

### 01200 English 9 - Accelerated

Open to grade 9

2 semesters, 1 credit per semester

Approximate cost per semester: \$20.85

Meets requirements: THD, AHD, Core 40, NCAA

Recommendation(s): Any student wishing to take Freshman Accelerated English is encouraged to have passed the 8th grade English ISTEP and have an A in 8th grade language arts or to have scored Pass+ and have an A or B in language arts.

Literature: The Odyssey; To Kill a Mockingbird; Romeo and Juliet; Great Expectations; the Prentice Hall anthology, short stories and poetry, also vocabulary studied through Latin and Greek roots

Assessments: Major papers, quizzes, tests, projects and presentations

### 01202 English 9 - College Prep

Open to grade 9

2 semesters, 1 credit per semester

Approximate cost per semester: \$21.85

Meets requirements: THD, AHD, Core 40, NCAA

Recommendation(s): In general, students who passed the ISTEP as eighth graders should choose this level.

Literature: Romeo and Juliet; Speak; The Odyssey; To Kill a Mockingbird; the Prentice Hall anthology, short stories and poetry

Assessments: Major papers, quizzes, tests, projects and presentations

### 01404 English 9 - Standard

Open to grade 9

2 semesters, 1 credit per semester

Approximate cost per semester: \$15.30

Meets requirements: THD, AHD, Core 40, NCAA

Recommendation(s): In general, students who did not pass ISTEP as eighth graders should choose the Standard level. This course is for students reading and writing below grade level.

Literature: Romeo and Juliet; Ellen Foster; Freak the Mighty; The Odyssey; the Prentice Hall anthology, short stories and poetry

Assessments: Major papers, quizzes, tests, projects and presentations

### 01505 English 9 - Standard 5

Open to grade 9

2 semesters, 1 credit per semester

Approximate cost per semester: \$15.12

Meets requirements: THD, AHD, Core 40

Recommendation(s): Students enroll in this course only when agreed upon by parents, teachers and counselor.

Literature: Freak the Mighty; Bearstone; On my Honor; the Prentice Hall anthology, poetry, short stories, plays, newspaper articles and independent reading projects

Assessments: Papers, quizzes, tests, projects and presentations

## SOPHOMORE CURRICULUM DESCRIPTION

The sophomore year includes a thematic study of world literature, composition (expository and creative), grammar and usage, spelling and vocabulary through root words and speech. Students use critical reading skills, listening skills, technology, research and the writing process throughout the year. All classes meet state standards and study much of the same literature. Accelerated classes move at a faster pace, cover more material, go into greater depth, and have more emphasis on style in writing than English 10. Standard classes focus more on basic skills related to the end of course assessment.

### **02005 English 10 - Accelerated**

**Open to grade 10**

**2 semesters, 1 credit per semester**

**Approximate cost per semester: \$46.35**

**Meets requirements: THD, AHD, Core 40, NCAA**

**Recommendation (s): A grade of A or B in English 9 Accelerated, or A in English 9 (college prep) and the motivation to work at a high level**

**Literature:** Two summer reading novels: (Siddhartha, The Glass Castle); The Old Man and the Sea; The Absolutely True Diary of a Part Time Indian; Cry, the Beloved Country; Crime and Punishment; The Things They Carried; Antigone; Macbeth; short stories, essays and poems

**Assessments:** Major papers (4-8 pages), oral presentations, projects, tests and quizzes

### **02212 English 10 – College Prep**

**Open to grade 10**

**2 semesters, 1 credit per semester**

**Approximate cost per semester: \$21.95**

**Meets requirements: THD, AHD, Core 40, NCAA**

**Literature:** Antigone, Siddhartha, The Old Man and the Sea, Cry the Beloved Country, Macbeth, short stories, essays and poems

**Assessments:** Major papers (4-5 pages), oral presentations, projects, tests, and quizzes

### **02414 English 10 - Standard**

**Open to grade 10**

**2 semesters, 1 credit per semester**

**Approximate cost per semester: \$19.80**

**Meets requirements: THD, AHD, Core 40, NCAA**

**Recommendation(s): This course is for students reading and writing below grade level.**

**Literature:** The Pearl; Miss Peregrine's Home for Peculiar Children; Out of the Dust; the Prentice Hall anthology, short stories, essays & poems

**Assessments:** Major papers (2-4 pages), oral presentations, projects, tests and quizzes

### **02515 English 10 - Standard 5**

**Open to grade 10**

**2 semesters, 1 credit per semester** **Approximate cost per semester: \$23.28**

**Meets requirements: THD, AHD, Core 40**

**Recommendation(s): Students enroll in this course only when agreed upon by parents, teachers and counselor.**

**Literature:** The Pearl; Downriver; poetry, short stories, the Prentice Hall Anthology, newspaper articles and independent reading projects

**Assessments:** Short papers, tests, quizzes and presentations

## **JUNIOR CURRICULUM DESCRIPTION**

The junior courses include a study of American Literature, composition (expository and creative) and speech. Students use critical reading skills, listening skills, technology, research and the writing process throughout the course. All classes meet state standards but differ in the content, depth, pace, approach and method of grading.

### **03005 AP Literature & Composition**

**Open to grade 11**

**2 semesters, 1 credit per semester**

**Approximate cost per semester: \$9.99**

**Meets requirements: THD, AHD, Core 40, GS, NCAA**

**Recommendations: Preferably grades of A or B in Sophomore Accelerated or grade of A in English 10**

**Note: It is expected that students who take this course will also take the AP Literature and Composition Test in May.**

**Literature:** One summer reading novel (Kite Runner); The Scarlet Letter; Slaughterhouse Five The Crucible; The Night Thoreau Spent in Jail; The Great Gatsby; Catcher in the Rye; numerous poems, essays, narratives and short stories

**Assessments:** Major papers (7-9 pages), oral presentations, projects, timed AP- style writings, tests and quizzes

### **03211 American Lit. 11–College Prep**

**Open to grade 11**

**1 semester, 1 credit**

**Approximate cost per semester: \$19.67**

**Meets requirements: THD, AHD, Core 40, NCAA**

**Literature:** The Crucible; The Great Gatsby; the Prentice Hall anthology, various short stories, essays, poems and narratives

**Assessments:** Major writing assignments, oral presentations, tests & quizzes

### **03411 American Lit. 11-Standard**

**Open to grade 11**

**1 semester, 1 credit**

**Approximate cost per semester: \$11.72**

**Meets requirements: THD, AHD, Core 40, NCAA**

**Recommendation(s): This course is for students reading and writing below grade level. This course is also for those students who will be retaking the 10th grade End of Course Assessment.**

**Literature:** Flygirl; Extremely Loud and Incredibly Close; the Prentice Hall anthology, various short stories, essays, poems and narratives

**Assessments:** Major writing assignments, an oral presentation, tests, and quizzes

## **JUNIOR ELECTIVES: Themes in Literature**

### **03221 American Literature: Free Thinkers (CP)**

**Open to grade 11**

**1 semester, 1 credit**

**Approximate cost per semester: \$11.72**

**Meets requirements: THD, AHD, Core 40, NCAA**

"Thinking outside the box"—philosophically questioning the way others think—is the theme that connects the literature in this course. Students will study authors, poets and statesmen who have caused significant change in the way people think.

**Literature:** The Catcher in the Rye; One Flew over the Cuckoo's Nest; the Prentice Hall anthology, stories, essays and poems

**Assessments:** Major writing assignments, a presentation, tests and quizzes

### **03223 American Literature: From Every Corner (CP)**

**Open to grade 11**

**1 semester, 1 credit**

**Approximate cost per semester: \$11.72**

**Meets requirements: THD, AHD, Core 40, NCAA, GS**

American authors from a variety of ethnic backgrounds are studied in this course. Through literature and composition, students study the ideas of a diverse group of authors.

**Literature:** The Joy Luck Club; The Chosen; Raisin in the Sun; the Prentice Hall anthology, assorted essays, stories and poems

**Assessments:** Major writing assignments, a presentation, tests and quizzes

### **03224 American Literature: American War Stories (CP)**

**Open to grade 11**

**1 semester, 1 credit**

**Approximate cost per semester: \$19.83**

**Meets requirements of: THD, AHD, Core 40, NCAA**

This course studies literature that reflects three different wars: World War I, World War II, and Vietnam.

**Literature:** Slaughterhouse Five, All Quiet on the Western Front, The Things They Carried, the Prentice Hall anthology, assorted stories, and poems.

**Assessments:** Major writing assignments, a presentation, test and quizzes

### **03225 Writer's Workshop (CP)**

**Open to grade 11**

**1 semester, 1 credit**

**Approximate cost per semester: \$30.00**

**Meets requirements: THD, AHD, Core 40, NCAA**

Students who love to write and students who want to improve all areas of their writing will want to take this course.

**Literature:** Crossroads: Creative Writing in Four Genres; a short story compilation reader

**Assessments:** Major writing assignments, multiple shorter writings

### **03422 American Literature: Adventure Awaits (S)**

**Open to grade 11**

**1 semester, 1 credit**

**Approximate cost per semester: \$34.70**

**Meets requirements: THD, AHD, Core 40, NCAA**

Literature of the outdoors is the focus of this course.

**Literature:** Into the Wild; When the Legends Die; the Prentice Hall anthology, assorted stories and poems

**Assessments:** Major writing assignments, presentation, tests & quizzes

### **03423 American Literature: American Mysteries (S)**

**Open to grade 11**

**1 semester, 1 credit**

**Approximate cost per semester: \$16.90**

**Meets requirements: THD, AHD, Core 40, NCAA**

Imagination, fantasy and strange twists abound in the literature of this course. Students will analyze these effects through the works of various authors.

**Literature:** Finding Lubchenko; The Maltese Falcon; The Face on the Milk Carton; the Prentice Hall anthology, various stories and poems

**Assessments:** Major writing assignments, a presentation, tests and quizzes

## **SENIOR CURRICULUM DESCRIPTION**

The senior year includes courses with an overview of British Literature--Senior Advanced Placement Language and Composition and British Masterpieces (CP)--as well as a course with a thematic look at problem solving--Senior Perspectives (S). Composition, vocabulary and speech are also included. Students use critical reading skills, listening skills, technology, research and the writing process throughout the course. All classes meet state standards but differ in the content, depth, speed of coverage, approach and method of grading. Standard level courses, both core and electives, address more basic skills in all areas of English.

### **04005 AP Language & Composition**

**Open to grade 12**

**2 semesters, 1 credit per semester**

**Approximate cost per semester: \$35.01**

**Meets requirements: THD, AHD, Core 40, NCAA, GS**

**Recommendation(s): Preferably grades of A or B in AP Literature and Composition or grade of A in Junior English**

**Note: It is expected that students who take this course will also take the AP Language and Composition Test in May.**

**Literature:** One summer reading novel (1984); Rosencrantz and Guildenstern Are Dead; Hamlet; and numerous non-fiction essays designed to prepare students for success on the AP test selections

College composition rhetoric, Aristotle's rhetorical triangle, and style will be taught.

**Assessments:** Major papers, the Senior Project Research Paper, rhetorical essays, timed AP Test style writing assignments, projects, tests and quizzes

### **03901 English 12 Composition - College Credit (W131)**

**Open to grade 12**

**1 semester, 1 credit per semester**

**Approximate cost per semester: \$28.50 + University Fees**

**Meets requirements: AHD, Core 40**

**Prerequisite: B- student recommended by counselor**

**Dual Credit: 3 hrs IU-Bloomington**

English 12 Advanced College Credit Project English is a one semester composition course that enables seniors to receive three hours of college credit at the same time that they fulfill half of their senior English requirement if they pay tuition set by Indiana University and earn a C or better in the course.

### **03902 English 12 Literature - College Credit (L202)**

**Open to grade 12**

**1 semester, 1 credit per semester**

**Approximate cost per semester: \$28.00 + University Fees Meets requirements: AHD, Core 40**

**Prerequisite: This course is open to students who have taken English W131 Dual Credit: 3 hrs IU-Bloomington**

English 12 Advanced College Credit Project English is a one semester literature course that enables seniors to receive three hours of college credit at the same time that they fulfill half of their senior English requirement if they pay tuition set by Indiana University and earn a C or better in the course. Students will be reading historical and cultural literature that will require literary analysis.

### **04200 British Masterpieces 12 - College Prep**

**Open to grade 12**

**1 semester, 1 credit**

**Approximate cost per semester: \$44.42**

**Meets requirements: THD, AHD, Core 40, NCAA**

**Literature:** Hamlet; Lord of the Flies; the Prentice Hall anthology, short stories and poems

**Assessments:** Major papers, the Senior Project Research Paper, an oral presentation, tests and quizzes

### **04600 Senior Perspectives 12 - Standard**

**Open to grade 12**

**1 semester, 1 credit**

**Approximate cost per semester: \$26.95**

**Meets requirements: THD, AHD, Core 40**

**Literature:** A Father's Law; For One More Day; and various short selections

**Assessments:** Major papers, the Senior Portfolio Research Paper, an oral presentation, tests and quizzes

## **SENIOR ELECTIVES: Themes in Literature**

### **04201 All about Now: A World in Conflict (CP)**

**Open to grade 12**

**1 semester, 1 credit**

**Approximate cost per semester: \$30.00**

**Meets requirements: THD, AHD, Core 40, NCAA, GS**

This course looks at current world issues through fiction and nonfiction.

**Literature:** A Thousand Splendid Suns; student choice of novels

**Assessments:** Major writing assignments, other writings, a presentation, tests and quizzes

### **04202 Big Brother (CP)**

**Open to grade 12**

**1 semester, 1 credit**

**Approximate cost per semester: \$30.00**

**Meets requirements: THD, AHD, Core 40, NCAA**

This course focuses on literature depicting governmental control, as well as utopian and dystopian societies.

**Literature:** 1984; Brave New World; Childhood's End

**Assessments:** Major writing assignments, other writings, a presentation, tests and quizzes

### **04205 Passages (CP)**

**Open to grade 12**

**1 semester, 1 credit**

**Approximate cost per semester: \$30.00**

**Meets requirements: THD, AHD, Core 40, NCAA**

This course examines rites of passage and stages of life depicted through literature.

**Literature:** Montana 1948; To Dance with the White Dog; St. Maybe

**Assessments:** Major writing assignments, other writings, a presentation, tests and quizzes

### **04601 Journeys: Young Adult Literature Survey (S)**

**Open to grade 12**

**1 semester, 1 credit**

**Approximate cost per semester: \$30.00**

**Meets requirements: THD, AHD, Core 40, NCAA**

This course studies how young adult literature addresses the "journey through life."

**Literature:** Staying Fat for Sarah Byrnes; Among the Hidden

**Assessments:** Major writing assignments, other writings, a presentation, tests and quizzes

**04602 Renegades (S)**

Open to grade 12

1 semester, 1 credit

Approximate cost per semester: \$30.00

Meets requirements: THD, AHD, Core 40, NCAA

This course looks at different styles of “heroes” as they are depicted in literature.

**Literature:** Fahrenheit 451; Monster;**Assessments:** Major writing assignments, other writings, a presentation, tests and quizzes**04603 Fantasy and Imagination (S)**

Open to grade 12

1 semester, 1 credit

Approximate cost per semester: \$30.00

Meets requirements: THD, AHD, Core 40, NCAA

This course studies literature created by imaginative and fantasy writers.

**Literature:** Big Fish; The Alchemist**Assessments:** Major writing assignments, other writings, a presentation, tests and quizzes

# MATHEMATICS

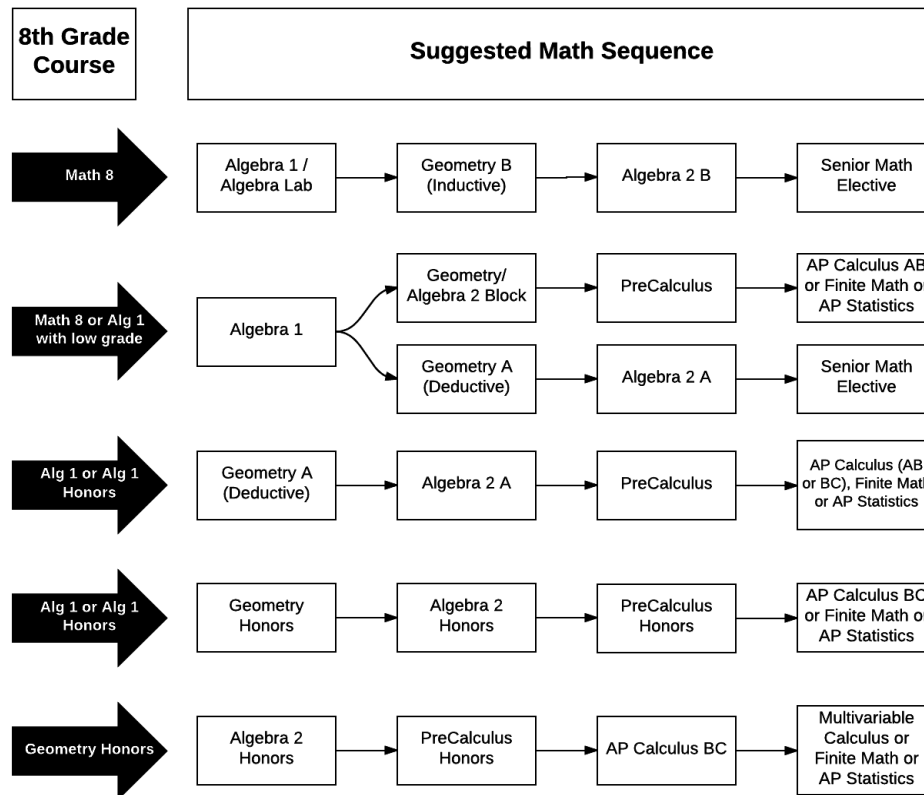

**SENIOR MATH ELECTIVES:** Bridge Math, Probability & Statistics, Trigonometry, Precalculus, & Finite Math

\*\*Successful completion of any path above meets the math requirements for a Core 40 Diploma.

\*\*Successful completion of paths 2,3,4 or 5 above meets the math requirements for an Academic Honors Diploma

## CREDIT FOR MATH IN MIDDLE SCHOOL

The purpose of offering Algebra 1 and Geometry in middle school is so that students can take advanced math courses during their senior year. Students performing poorly in Algebra 1 in grade 8 are strongly encouraged to retake the course during their freshman year. Freshmen entering high school are required to take a mathematics course each year in high school. This requirement can be satisfied with a quantitative course such as physics.

## “DOUBLING UP” IN MATH

In an effort to make more progress in mathematics, students often choose to “double up.” They take two math classes in one year. Teacher recommendation is required for any of these “doubling up” plans:

- Sophomores who took Algebra 1 in their freshman year can reach a college level senior elective math course by taking Geometry/Algebra 2 Block (11312 & 11313). This option is also available to some freshman with special permission from the department chair.
- After taking Precalculus any student may “double up” by taking two math electives including AP Calculus, AP Statistics, Finite Math, and Computer Science.

Any effort to “double up” in order to complete math requirements early so that no math course is taken senior year is not advised. It is contrary to Department of Education directives. College admissions offices strongly recommend a math course during the senior year.

**11001 Algebra 1 Lab**

Open to grades 9, 10

2 semesters, 1 credit per semester

Approximate cost per semester: 15.50 Meets no graduation requirements Prerequisite(s): none

This course is a support class for Algebra 1 (11301) for students who have struggled with math in the past.

**11301 Algebra 1**

Open to grades 9,10,11,12

2 semesters, 1 credit per semester

Approximate cost per semester: \$12.34

Meets requirements: THD, AHD, Core 40, NCAA

Prerequisite(s): Successful completion of 8th grade mathematics and recommendation of 8th grade math teachers.

This is the first math course required of a Core 40 diploma. This class extends the algebra studied in middle school. Students will learn to solve linear and quadratic equations. Students will graph and interpret graphs of lines and parabolas. A scientific (not graphing) calculator is required.

**11204 Algebra Recovery**

Open to grades 10,11,12

1 semester, 1 credit per semester

Approximate cost per semester: \$15.50

Meets requirements: THD, AHD, Core 40, NCAA

Students who fail Algebra 11301 in the spring can retake it as this course in the fall. This is second semester Algebra offered during first semester. This course can be taken concurrently with Inductive Geometry 11103.

**11103 Geometry-B (An Inductive Approach)**

Open to grades 10,11,12

2 semesters, 1 credit per semester

Approximate cost per semester: \$12.34

Meets requirements: THD, AHD, Core 40, NCAA

Prerequisite(s): Successful completion of Algebra 1 and teacher recommendation

Note: May be taken concurrently with 11301 Algebra

1 by upperclassmen with teacher recommendation or department chair permission.

This course takes geometry concepts studied in middle school to a higher level. Topics include angles, lines, planes, and shapes. Students will also study 3-dimensional solids and right triangle trigonometry. There is less emphasis on formal proof than in course 11302. There is a greater emphasis on real applications. This course is not open to any student who took algebra in 8th grade. Those students should take the more rigorous Deductive Geometry (11302) or Honors Geometry (11525).

**11302 Geometry A (A Deductive Approach)**

Open to grades 9,10,11

2 semesters, 1 credit per semester

Approximate cost per semester: \$12.34

Meets requirements: THD, AHD, Core 40, NCAA

Prerequisite(s): Successful completion of Algebra 1 and Algebra teacher recommendation

This course takes geometry concepts studied in middle school to a higher level. Topics include angles, lines, planes, and shapes. Students will also study 3-dimensional solids and right triangle trigonometry. There is a strong emphasis on reasoning as students prove geometric properties. Students will use geometry software and spreadsheets. Note: May be taken concurrently with 11303 Algebra 2 with teacher recommendation or department chair permission, however, students interested in taking Algebra 2 and Geometry concurrently are encouraged to take the block class (11312 and 11313).

**11525 Geometry- Honors**

Open to grade 9, 10

2 semesters, 1 credit per semester

Approximate cost per semester: \$12.34

Meets requirements of: THD, AHD, Core 40, NCAA

Prerequisite(s): Successful completion of Algebra 1 or Algebra 1 Honors in grade 8, teacher recommendation

This is a challenging geometry course. It is enriched and faster paced than the other geometry courses. A strong emphasis will be placed on student inquiry and reasoning. Students will tackle challenging problems and complete in-depth investigations. Geometric computer software will be used extensively and spreadsheets will be incorporated as a problem-solving tool.

**11313/11312 Geometry/ Algebra 2 Block**

Open to grade 9,10

2 semesters, 2 credits per semester (2 periods)

Approximate cost per semester: \$18.14

Meets requirements: THD, AHD, Core 40, NCAA

Prerequisite(s): Successful completion of 12131 Algebra 1 and teacher recommendation

Note: May be taken grade 9 w/department chair approval

This course provides an option for students who are "doubling up" in Geometry and Algebra 2. Geometry is completed during the first semester and Algebra 2 is completed during the second semester. This class takes two periods each semester. The reason for "doubling up" is to prepare students beginning with Algebra 1 freshman year to take an AP or dual credit math elective during their senior year. This plan requires strong math skills and interest in mathematics. It also requires good study skills. The curriculum is identical to 11302 Geometry and 11303 Algebra 2. A TI83+ or TI84 graphing calculator will be required for second semester.

**11104 Algebra 2 - B**

Open to grades 11,12

2 semesters, 1 credit each semester Approximate cost per semester: \$23.93

Meets requirements: THD, AHD, Core 40, NCAA

Prerequisite(s): Successful completion of Geometry and teacher recommendation

Note: Any student planning to take Calculus as a senior by "doubling up" Geometry and Algebra 2 should sign up for 11302 Geometry and 11303 Algebra 2 or Geometry/Algebra 2 Block (11312 & 11313).

This course adds to the algebra learned in Algebra 1. This class is for students who will not study advanced math, science, or technology in college. Topics include absolute value, quadratic, polynomial, logarithmic and exponential functions. The course also covers algebraic fractions, sequences and series. Students apply the math to real situations. Communication and reasoning are important. A TI83+ or TI 84 graphing calculator is required.

**11303 Algebra 2 - A**

Open to grades 9, 10,11

2 semesters, 1 credit each semester

Approximate cost per semester: \$23.93

Meets requirements: THD, AHD, Core 40, NCAA

Prerequisite(s): Successful completion of Geometry and teacher recommendation

This course adds to the algebra learned in Algebra 1. Topics include absolute value, quadratic, polynomial, logarithmic and exponential functions. The course also covers algebraic fractions, sequences and series. Students apply the math to real situations. Communication and reasoning are important. This course is more theoretical and abstract in its approach than 11104. This theory and abstraction is important for students planning to take Precalculus. A TI83+ or TI 84 graphing calculator is required.

### **11515 Algebra 2- Honors**

**Open to grades 9,10**

**2 semesters, 1 credit per semester**

**Approximate cost per semester: \$23.29**

**Meets requirements: THD, AHD, Core 40, NCAA**

**Prerequisite(s): Successful completion of Geometry Honors and recommendation of math teacher**

This course adds to the algebra learned in Algebra 1. Topics include absolute value, quadratic, polynomial, logarithmic and exponential functions. The course also covers algebraic fractions, sequences and series. Students apply the math to real situations. This class is faster paced and more challenging than the other Algebra 2 options.

Communication and reasoning are important. A TI83+ or TI 84 graphing calculator is required.

### **11310 Finite Math**

**Open to grade 11, 12**

**2 semesters, 1 credit per semester**

**Approximate cost per semester: \$16.53**

**Meets requirements of: THD, AHD, Core 40, NCAA**

**Prerequisite(s): Successful completion of Algebra 2**  
**Recommendation(s): Teacher recommendation Note: Early college credit is available.**

Finite Mathematics prepares students for the mathematics used in social science and business. It prepares students for college statistics. This course is a good option for students planning to pursue most college majors. This includes social science, business, and humanities majors. The course follows the curriculum of M118, Finite Mathematics, from Indiana University. This includes linear regression, matrices, linear programming, and probability. There is an emphasis on applications and mathematical modeling. A TI83+ or TI84 graphing calculator is required. This course may be offered as M118 Finite Mathematics from Indiana University for 3 sem. hrs. credit fulfilling a business major requirement for Indiana University.

### **11314 Precalculus/Trigonometry**

**Open to grades 11,12**

**2 semesters, 1 credit per semester**

**Approximate cost per semester: \$18.83**

**Meets requirements: THD, AHD, Core 40, NCAA**

**Prerequisite(s): Successful completion of Algebra 2 and teacher recommendation**

**Note: Early college credit is available.**

This course is for students who will be taking calculus in high school or college. Precalculus is especially appropriate for students planning to major in mathematics, engineering, computer science or science related fields. The course centers on the study of functions. This includes polynomial and rational functions. It also includes exponential, logarithmic, and trigonometric functions. To emphasize real-world connections, data analysis will be incorporated throughout the course. Verbal and written communication will be emphasized along with mathematical reasoning, and problem solving. A TI83+ and TI84 graphing calculator is required. This course may be offered for 6 semester hours of credit as M136 College Algebra, and M137 Trigonometry with Analytic Geometry through Ivy Tech Community College.

### **11535 Precalculus/Trigonometry - Honors**

**Open to grade 10, 11**

**2 semesters, 1 credit per semester**

**Approximate cost per semester: \$18.83**

**Meets requirements: THD, AHD, Core 40, NCAA**

**Prerequisite(s): Successful completion of Algebra 2 Honors or Algebra 2 and teacher recommendation**

**Note: Early college credit is available.**

This course is for students who will be taking AP Calculus. Precalculus is especially appropriate for students planning to major in mathematics, engineering, computer science or science related fields. The course centers on the study of functions. This includes polynomial and rational functions. It also includes exponential, logarithmic, and trigonometric functions. Parametric equations, polar coordinate equations, and sequences, and series are also included. To emphasize real-world connections, data analysis will be incorporated throughout the course. Verbal and written communication will be emphasized along with mathematical reasoning, and problem solving. A TI83+ and

TI84 graphing calculator is required. This course may be offered for 6 semester hours of credit as M136 College Algebra and M137 Trigonometry with Analytic Geometry through Ivy Tech Community College.

### **11105 CCR Bridge: Math Ready**

**Open to grade 12**

**2 semesters, 1 credit per semester**

**Approximate cost per semester: TBD**

**Meets requirements: THD, AHD, Core 40, NCAA**

**Prerequisite(s): Credit in Algebra 1, Geometry, Algebra 2 and teacher recommendation**

This course will reinforce mathematics procedures and concepts from algebra, geometry, and statistics in real-world contexts that deepen students' understandings. This course covers some trigonometry topics, but does not satisfy the trigonometry requirement for admission into some colleges and universities, such as Indiana University. That requirement is met by 11306, 11314, or 11535. A graphing calculator is required.

### **11306 Trigonometry**

**Open to grades 11,12**

**1 semester, 1 credit per semester**

**Approximate cost per semester: \$18.83**

**Meets requirements: THD, AHD, Core 40, NCAA**

**Prerequisite(s): Successful completion of Algebra 2 or Algebra 2 Honors and teacher recommendation**

This course extends the study of trigonometry that was begun in Geometry. The study of trigonometry is extended to triangles beyond right triangles and to circular functions. The graphs of all six trigonometric functions and their inverses will be included. This course prepares students for college placement tests and post-secondary study in any technical field. Technology is an integral part of this course and a TI83+ graphing calculator will be required. The topics in this one semester class are also included in the second semester of Precalculus. A TI83+ and TI84 graphing calculator is required.

### **11305 Probability and Statistics**

**Open to grades 11,12**

**1 semester, 1 credit per semester**

**1 Approximate cost per semester: \$15.62**

**Meets requirements: THD, AHD, Core 40, NCAA, GS**

**Prerequisite(s): Successful completion of Algebra 2 or Algebra 2 Honors and teacher recommendation.**

Probability and Statistics includes the concepts and skills needed to apply statistical techniques in the decisionmaking process. Probability and Statistics are made up of three strands: Data Analysis, Experimental Design, and Probability. Practical examples based on real experimental data are used throughout. Students plan and conduct experiments or surveys and analyze the resulting data. The use of graphing calculators and computer programs is encouraged. The eight Process Standards for Mathematics apply throughout the course. Together with the content standards, the Process Standards prescribe that students experience mathematics as a coherent, useful, and logical subject that makes use of their ability to make sense of problem situations.

### **17350 AP Statistics**

**Open to grades 11,12**

**2 semesters, 1 credit per semester**

**Approximate cost per semester: \$15.62**

**Meets requirements: THD, AHD, Core 40, NCAA, GS Prerequisite(s): Successful completion of Algebra 2**

This course follows the AP Statistics curriculum and all students will take the AP Statistics test in the spring with the opportunity of earning up to three hours of college credits. Statistics is used in the social sciences and natural sciences. It is also used in business and journalism. This course should be of practical use for anyone considering a career in any of those areas as well as science, engineering, medicine, sociology, economics, education and many other fields. For many college majors, this course is as appropriate as or even more appropriate than Calculus. The course may be taken concurrently with Precalculus or Calculus. A TI83+ or TI84 graphing calculator is required.



### 11315 AP Calculus AB

Open to grades 11,12

2 semesters, 1 credit per semester

Approximate cost per semester: \$20.37

Meets requirements: THD, AHD, Core 40, NCAA

Prerequisite(s): Successful completion of 11535 Precalculus Honors or 11314 Pre-calculus+teacher recommendation

Calculus 1, Advanced Placement and College Credit

This is a rigorous college level calculus course that is the basis for many fields of study in college including the further study of mathematics or science. Topics include limits, continuity, derivatives and integrals. An emphasis is placed on graphical interpretation and understanding of calculus concepts and on the application of those concepts in problems from many fields of study. Calculus AB is equivalent to a first semester college calculus course. Choosing between AP Calculus and AP Statistics should be based on possible college majors. For some areas of study like social sciences and humanities, Statistics is more appropriate. For other areas like science, technology, or engineering, Calculus is more appropriate. For college majors in business, both Calculus and Statistics are required at the college level. AP Calculus and AP Statistics may be taken concurrently. Successful completion of the Advanced Placement Calculus Test in the spring can result in one semester of credit from many colleges and universities. A TI83+ or TI84 graphing calculator is required. This course may be offered for college credit through Ivy Tech Community College.

### 11545 AP Calculus BC

Open to grades 11,12

2 semesters, 1 credit per semester

Approximate cost per semester: \$20.37

Meets requirements of: THD, AHD, Core 40, NCAA

Prerequisite(s): Successful completion of 11535 Precalculus, Honors or 11314 Precalculus + teacher recommendation

Calculus 1&2, Advanced Placement and College Credit

Calculus BC is a faster-paced alternative to Calculus AB; common topics require a similar depth of understanding. The curriculum covered in Calculus BC will equate to a full year of a typical college calculus course. The course will emphasize a multi-representational approach to calculus, with concepts, results and problems being expressed geometrically, numerically, analytically, and verbally. The connections among these representations will be emphasized. All topics from AP Calculus AB will be included along with more advanced topics. Choosing between AP Calculus and AP Statistics should be based on possible college majors. For some areas of study, like social sciences and humanities, Statistics is more appropriate. For other areas like science, technology, or engineering, Calculus is more appropriate. AP Calculus and AP Statistics may be taken concurrently. For college majors in business, both Calculus and Statistics are required at the college level. Successful completion of the Advanced Placement Calculus Test in the spring can result in one or two semesters of college credit from many colleges or universities. Technology is an integral part of this course and a TI83+ graphing calculator will be required. This course may be offered for 8 semester hours of credit as M211 Calculus 1 and M212 Calculus 2 through Indiana University. University costs will apply.

### 11600 Multivariable Calculus

Open to grade 12

2 semesters, 1 credit per semester

Approximate cost per semester: \$22.95

Meets requirements: THD, AHD, Core 40, NCAA

Prerequisite(s): AP Calculus BC with an AP score of 4 or 5 and teacher recommendation

College credit for this class can be earned at some universities through "credit by exam."

Multivariable Calculus continues the study of Calculus by expanding many of the topics covered in AP Calculus BC to three or more variables. Topics include multivariable functions, vectors, differentiation, integration, and different coordinate systems include polar, cylindrical, and spherical. A TI83+,TI84, or TI89 calculator is required for this class.

### 16111 AP Computer Science Principles

Open to Grades 9, 10, 11, 12

2 semesters, 1 credit per semester

Approximate cost per semester: \$7.45

Meets requirements of: THD, AHD, Core 40 Elective, NCAA, GS

Prerequisite(s): A grade of C or better in Algebra

Note: This course does not fulfill a mathematics requirement for graduation

AP Computer Science Principles introduces students to the essential ideas of computer science with a focus on how computing can impact the world. The rigorous course develops computational thinking skills, while also engaging in the creative aspects of the field. Students will learn to analyze data, information or knowledge represented for computational use; develop and analyze algorithms; create technology that has a practical impact; and gain a broader understanding of how computer science impacts people and society. The AP exam for this course consists of electronic submission of artifacts created throughout the year as well as a multiple choice test at the end of the year.

### 16121 AP Computer Science A

Open to grades 10,11,12

2 semesters, 1 credit per semester

Approximate cost per semester: \$7.45

Meets requirements: THD, AHD, Core 40 Elective, NCAA, GS

Prerequisite(s): A grade of C or better in Algebra

Note: This course does not fulfill a mathematics requirement for graduation.

The first year course focuses on programming fundamentals with advanced topics being presented in the second semester. Students will learn the basis of Java, data structures, algorithms and object oriented programming. Students will use programming as a problem-solving tool as they subdivide programs into manageable parts and search for creative and logical solutions to programming problems. This course will cover the curriculum tested on the AP Computer Test which students may opt to take at the end of year 1 or at the end of year 2. In years 2 and 3 students will advance their programming skills by working on advanced programming projects with multiple programmers.



# SCIENCE

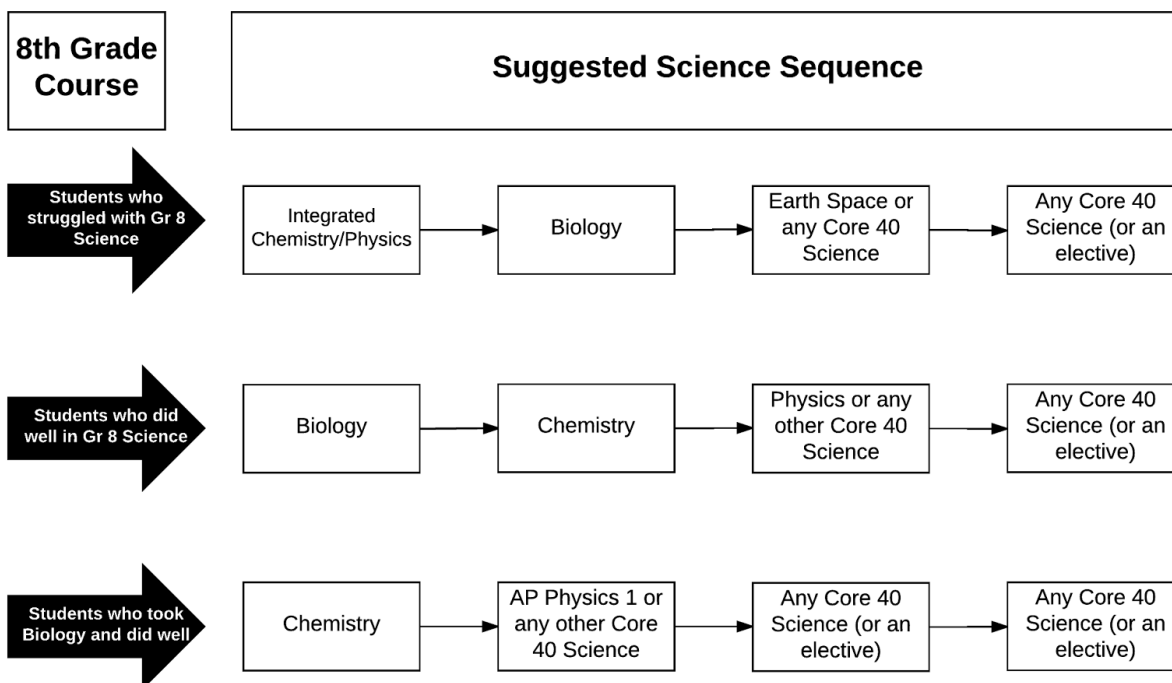

*\*Some post secondary institutions have specific science entrance requirements. It is important to check with the institution you are interested in attending to make sure you meet all entrance requirements.*

## 23401 Integrated Chemistry-Physics

Open to grades 9,10,11,12

2 semesters, 1 credit per semester

Approximate cost per semester: \$20.00

Meets requirements: THD, AHD, Core 40, NCAA

Integrated Chemistry-Physics is an introductory level course in which students explore fundamental physics and chemistry principles. Students enrolled in this course use scientific inquiry to examine forces and motion, the structure and properties of matter, chemical reactions, and the interactions between energy and matter. These topics will be explored via classroom discussion, laboratory activities, hands on activities, short video clips, classroom work and virtual investigations.

**\*Note, students enrolled in Algebra 2 or above, or students who have already earned credit in either 22401 Chemistry 1 or 24111 Physics 1 are not eligible to also earn credit in ICP. ICP also does not substitute for chemistry or physics for college entrance requirements.**

## 23101 Earth and Space Science

Open to grades 10,11,12

2 semesters, 1 credit per semester

Approximate cost per semester: \$29.06

Meets requirements: THD, AHD, Core 40, NCAA, GS

In first semester Earth and Space Science, students study the Earth, and the processes that shape the Earth. Students study how the Earth operates as a collection of connected systems. Student will learn that some of those systems are changing while others are in equilibrium. In second semester Earth & Space Science, students study the concepts of energy, matter, conservation and gravity. Students apply these concepts to the Earth, solar system, and universe. Students also develop a concept of scale of time and size for the Earth, planets, and stars.

## 23302 Earth and Space Science 2: Astronomy

Open to grades 11, 12

2 semesters, 1 credit per semester

Approximate cost/semester: \$10 lab fee + text rental fee

Meets requirements: THD, AHD, and Core 40

**Prerequisite(s) 1 year of physical science (Earth Space 1, Chemistry 1, or Physics 1) AND completion of Algebra 1 earning a C or higher**

Astronomy is a mathematically research-based class. First semester will cover ancient and historical astronomy, observational astronomy, planetology, smaller bodies, and solar system development. Second semester will include stellar development, galactic development, The Big Bang Theory, cosmology, and astrobiology.

## 21401 Biology I

Open to grades 9,10,11,12

2 semesters, 1 credit per semester

Approximate cost per semester: \$19.84

Meets requirements: THD, AHD, Core 40, NCAA

Biology I is the study of the natural world and the living organisms within it. To enable students to understand life and its interactions, the course explores the concepts, principles, and theories of biology, including cell theory, evolution, gene theory, energy, and ecology. The complexity of life on Earth will be investigated via a variety of methods that promote active learning, student engagement and critical thinking skills.

## **21451 Zoology**

**Open to grades 10,11,12**

**2 semesters, 1 credit per semester**

**Approximate cost per semester: \$10.00**

**Meets requirements: THD, AHD, Core 40, NCAA Prerequisite: Successful completion of Biology 1**

Zoology is an in-depth study of the classification, anatomy, and physiology of animals through comparative analysis. Topics include evolution, development, and various body systems and their organs. Structure and function will be emphasized. Students will spend some time learning about varying degrees of tissue specialization and the levels of organization of invertebrate animals such as sponges, starfish, earthworms, snails, mussels, crayfish, and grasshoppers. The majority of the course will be devoted to expanding these concepts of tissue structure and function to vertebrate animals. Students in the course will participate in extensive laboratory dissections of both vertebrates and invertebrates.

## **21411 Human Anatomy & Physiology**

**Open to grades 10, 11,12**

**2 semesters, 1 credit per semester**

**Approximate cost per semester: \$38.74**

**Meets requirements: THD, AHD, Core 40, NCAA**

**Prerequisite(s): Biology 1 with a C- or better & Chem 1**

This course provides an in-depth investigation of the structure and interaction of body systems, their related diseases, and treatment. Students gain basic knowledge of the skeletal, muscular, nervous, cardiovascular, and other body systems utilizing text, labs, and dissection. Through the application of course concepts, students will be able to discuss current medical issues and use this information to make responsible decisions to enhance their personal lives.

## **20220 AP & College Credit Biology**

**Open to grades 11, 12**

**2 Semesters, 1 credit per semester**

**Approximate cost per semester: \$24.38**

**Meets requirements: THD, AHD, Core 40, NCAA**

**Prerequisite(s): 2 semesters of Biology 1 & 2 semesters of Chemistry 1**

Curriculum for this course follows College Board Entrance Examination Guidelines for AP Biology and is offered for the college-bound student who needs a rigorous treatment of college-level Freshman Biology. Students may elect to take the Advanced Placement test at the end of the year for possible college credit. The curriculum also follows Indiana University's guidelines for BIOL-L100 Humans and the Biological World. Students may elect to earn 5 hours of college credit through IU.

## **214600 AP Environmental Science**

**Open to grades 11, 12**

**2 Semesters, 1 credit per semester**

**Approximate cost per semester: \$25.00**

**Meets requirements: THD, AHD, Core 40, NCAA, GS**

**Prerequisite(s): 2 credits in Algebra, 2 credits in Biology, 2 credits in another science course**

This is a course based on content established by the College Board. Students enrolled in AP Environmental Science investigate the scientific principles, concepts, and methodologies required to understand the interrelationships of the natural world, to identify and analyze environmental problems both natural and human-made, to evaluate the relative risks associated with these problems, and to examine alternative solutions for resolving and/or preventing them. This course is designed to be the equivalent of a one semester, introductory college course in environmental science.

## **22401 Chemistry I**

**Open to grade 9, 10,11,12**

**2 semesters, 1 credit per semester**

**Approximate cost per semester: \$19.52**

**Meets requirements: THD, AHD, Core 40, NCAA**

This is a laboratory based course that is concerned with the composition, behavior, structure, and properties of matter. This course explores the reactions between substances, the periodic trends in the chemical reactivity, energy exchanges, and the laws that unite these events into a unified and comprehensive system. Because chemistry

provides an important understanding of how the world around us works, it has a large impact on our daily living. Understanding chemistry helps students better understand many matters of both private and public concern.

## **22400 AP Chemistry**

**Open to grades 11,12**

**2 semesters, 1 credit per semester**

**Approximate cost per semester: \$45.40**

**Meets requirements: THD, AHD, Core 40, NCAA**

**Prerequisite(s): Chemistry I**

Curriculum for this course follows College Board Entrance Exam Guidelines for AP Chemistry and is offered for the college bound student who needs a rigorous treatment of college level Freshman Chemistry. Students may elect to take the Advanced Placement test at the end of the year for possible college credit. Students should take AP Chemistry if they plan to major in science in college.

## **22402 Chemistry 2 & College Credit Chemistry**

**Open to grades 11,12**

**2 semesters, 1 credit per semester**

**Approximate cost per semester: \$45.40 (+ \$125.00 to IU for College Credit)**

**Meets requirements: THD, AHD, Core 40, NCAA**

**Prerequisite(s): Chemistry I**

Curriculum for this course follows the curriculum at Indiana University for C101/C121 freshman college chemistry for nonscience majors. This course is also taken for 5 hours credit at Indiana University (3 credit hrs for the lecture course C101 & 2 credit hrs for the laboratory course C121). Topics include, Chemistry & Measurement, Atoms, Elements, Molecules & Compounds, Nuclear Chemistry, Chemical Bonding, Introduction to Chemical Reactions, Thermochemistry, Chemical Equilibrium, Gases, Liquids & Solids & Phase Changes, and Acids & Bases.

## **24111 Physics I**

**Open to grades 9, 10,11,12**

**2 semesters, 1 credit per semester**

**Approximate cost per semester: \$19.76**

**Meets requirements: THD, AHD, Core 40, NCAA**

**Prerequisite(s): A minimum of a C in Algebra**

**\*Important note\* This course is intended for students who do not plan to major in science or engineering in college. Those students enrolled in PreCalculus or higher math should take AP Physics 1 (course #24241) instead.**

First semester physics topics include linear motion, Newton's first law, Newton's second law, Newton's 3rd law, energy, buoyancy, gravity, and the history of physics. Physics is a very lab intensive, hands-on course. A boat project and an energy or vehicle construction project is completed during the year. Second semester physics topics are projectile motion, momentum, circular motion, rotational mechanics, light and sound, center of gravity. This course is intended for students who do not plan to major in science or engineering in college.

## **24211 AP Physics 1**

**Open to grades 9, 10,11,12**

**2 semesters, 1 credit per semester**

**Approximate cost per semester: \$19.76**

**Meets requirements: THD, AHD, Core 40, NCAA**

**Prerequisite(s): Concurrent enrollment in Algebra 2 or higher math class. Students can elect to earn the AP Physics 1 exam credit. It is more mathematical in nature than Physics 1 and the class moves at a faster pace.**

First semester topics include linear motion, Newton's first law, Newton's second law, Newton's 3rd law, energy, vectors, and buoyancy. A boat project and an energy or vehicle construction project will be completed during the year. Second semester includes gravitation, momentum, circular and rotational motion, waves and sound, and electricity and magnetism. Laboratory experimentation and demonstrations is emphasized and comprises 50% or more of class time. Students will become skilled at modeling physics using graphical and mathematical means. Conceptual physics will be taught with an emphasis on observational, mathematical, and data collection skills.

## **24402 AP Physics C & College Credit Physics**

**Open to grades 11,12**

**2 semesters, 1 credit per semester**

**Approximate cost per semester: \$22.07**

**Meets requirements: THD, AHD, Core 40, NCAA**

**Prerequisite(s): 24211 AP Physics 1, or 24111 Physics 1 with instructor approval**

Curriculum for this course follows College Board Entrance Exam Guidelines for AP C Physics-Mechanics. It also follows the Indiana University Advanced College Project requirements for Physics - P221 and students can elect to earn 5 credit hours from Indiana University for this course. Course content and technical applications will be explored through group work and laboratory experiments. This class will help students become competent in utilizing math concepts to support the study of advanced physics topics. Topics include: kinematics with vectors, dynamics, circular motion, work & energy, linear momentum, rotational motion, oscillations, equilibrium, and electricity and magnetism concepts. Students preparing for the AP C Electricity and Magnetism Physics exam will also study Electrostatics, Capacitors, Conductors, Dielectrics, Electric Circuits, Magnetism, and Electromagnetism.

## **C4 Science Courses**

### **T25501 Advanced Life Science: Animals**

**Open to grades 11, 12**

**2 semesters, 1 credit per semester**

**Approximate cost per semester: \$25.77**

**Meets requirements: THD, AHD, Core 40, NCAA Recommendation(s):**

**Two years of Core 40/AHD Science Note: This course counts toward Core 40 Science credits.**

This is a standards-based, interdisciplinary science course that integrates biology, chemistry, and microbiology in an agricultural context. Students formulate, design, and carry out animal-based laboratory and field investigations. They investigate key concepts that enable them to understand animal growth, development, and physiology as it pertains to agricultural science. Students will be able to apply the principles of scientific inquiry to solve problems related to biology and chemistry in highly advanced agricultural applications of animal development.

### **T25502 Advanced Life Science: Foods**

**Open to grades 11, 12**

**2 semesters, 1 credit per semester (may include travel period)**

**Approximate cost per semester: \$68.38**

**Meets requirements: THD, AHD, Core 40, NCAA Recommendation: Two years of Core 40/AHD Science Note: This course counts toward Core 40 Science credits.**

**Note: Qualifies as a Quantitative Reasoning course for the General, Core 40, AHD and THD diplomas.**

This two-semester course provides students with opportunities to participate in a variety of activities including laboratory work. This is a standards-based, interdisciplinary science course that integrates biology, chemistry and microbiology in the context of foods and the global food industry. Students formulate, design and carry out food-based laboratory and field investigations. Students understand how biology, chemistry and physics principles apply to the composition of foods, the nutrition of foods, food and food product development, food processing, food safety and sanitation, food packaging and food storage. Students will be able to apply the principles of scientific inquiry to solve problems related to biology, physics and chemistry in the context of highly advanced industry applications of foods.

### **T56101 PLTW Principles of the Biomedical Sciences**

**Open to grades 9, 10, 11, 12**

**2 semesters, 1 credit per semester**

**Approximate cost per semester: \$52.44**

**Meets requirements: THD, AHD, Core 40**

**Prerequisites: Enrolled in Biology, college prep math and science Dual Credit Available**

**Note: This course counts towards Core 40 science credits.**

Students explore the concepts of human medicine and are introduced to research processes, using applied math and science to solve problems. Hands-on, interactive projects enable students to

investigate human body systems and various health conditions, including heart disease, diabetes, sickle-cell disease, hypercholesterolemia and infectious diseases. Key biological concepts include homeostasis, metabolism, inheritance of traits, feedback systems and defense against disease. Engineering principles such as the design process, feedback loops, fluid dynamics and the relationship of structure to function will be included where appropriate.

### **T56201 PLTW Human Body Systems**

**Open to grades 10, 11, 12**

**2 semesters, 1 credit per semester**

**Approximate cost per semester: \$52.44**

**Meets requirements: THD, AHD, Core 40**

**Recommendation(s): PLTW Principles of the Biomedical Sciences**

**Prerequisites: College prep math and science**

**Dual Credit Available**

**Note: This course counts towards Core 40 science credits.**

Students learn anatomy and physiology of the human body through a hands-on approach. Using real-world cases, students take the role of a biomedical professional to work together to solve medical mysteries. Hands-on, interactive projects include designing experiments, investigating the function and structures of the human body through dissections, clay modeling, laboratory analysis and using data acquisition software to monitor body functions such as reflex, muscle movement and lung capacities. Students learn to assess and monitor body systems and how they work together.

### **T56301 PLTW Medical Interventions**

**Open to grades 11, 12**

**2 semesters, 1 credit per semester**

**Approximate cost per semester: \$52.44**

**Meets requirements: THD, AHD, Core 40**

**Prerequisites: Principles of the Biomedical Sciences, Human Body Systems and/or Anatomy and Physiology**

**Dual Credit Available**

**Note: This course counts towards Core 40 science credits.**

Students investigate various medical interventions that extend and improve the quality of life including gene therapy, pharmacology, surgery, prosthetics, rehabilitation and supportive care. The course explores the design and development of various medical interventions such as vascular stents, cochlear implants and prosthetic limbs. In addition, students review the history of organ transplants and gene therapy and stay updated on cutting-edge developments via current scientific literature. Using 3D imaging, data acquisition software and current scientific research, students design a product that can be used as a medical intervention.

### **T56401 PLTW Biomedical Innovation**

**Open to grades 11, 12**

**2 semesters, 1 credit per semester**

**Approximate cost per semester: \$52.44**

**Meets requirements: THD, AHD, Core 40**

**Prerequisites: Human Body Systems, Anatomy and Physiology or**

**Medical Interventions**

**Dual Credit Available**

**Note: This course counts towards Core 40 science credits.**

**Note: With approval, qualified PLTW student may use this project for**

**their Senior Project at CEHS and CNHS.**

Biomedical Innovation is the fourth and final Project Lead the Way Biomedical Science course. It is intended to follow the third course, Medical Interventions. In this capstone course students will design and conduct experiments related to the diagnosis, treatment and prevention of disease or illness. They will apply their knowledge and skills to answer questions or to solve problems related to the biomedical sciences. They will work to design an effective emergency room, explore human physiology and design a medical innovation. They will investigate public health issues and forensic autopsy. They may work with a mentor or advisor from a university, hospital, physician's office or industry as they complete

# SOCIAL STUDIES

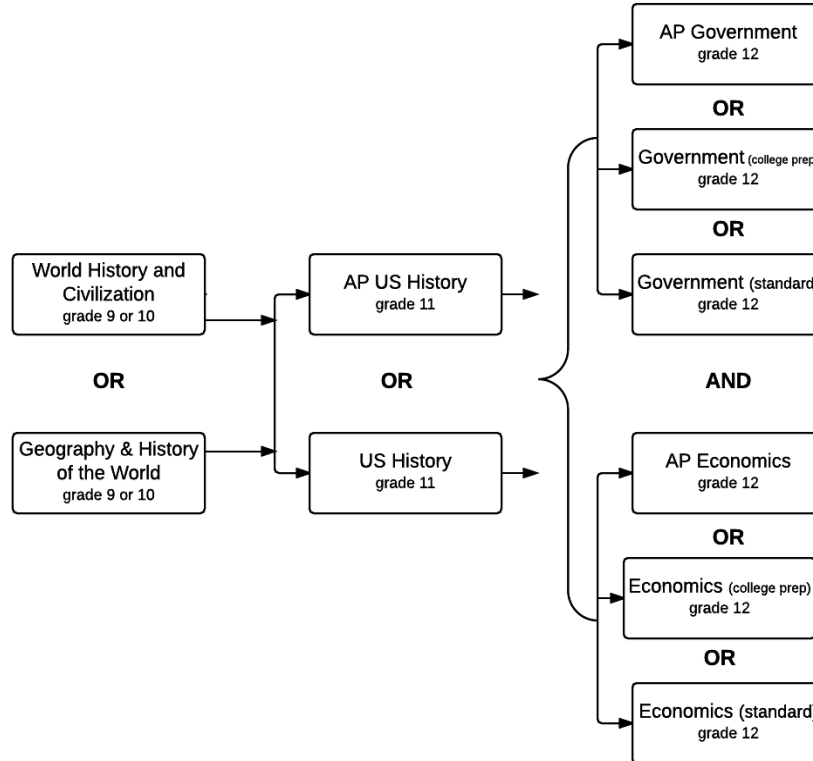

## FRESHMEN & SOPHOMORES

### 31101 World History and Civilization

Open to grades 9, 10

2 semesters, 1 credit per semester

Approximate cost per semester: \$5.63

Meets requirements: AHD, THD, Core 40, NCAA, GS

Students will study turning points in history that have affected a large amount of people around the globe. In this college prep class, students will be expected to practice a historical way of thinking such as understanding chronology, critical thinking and cause and effect. Students will source, corroborate, and contextualize a variety of primary sources and be asked to make applications of historical learning to modern day issues. Common topics studied include world religions, types of government, war and peace, and the rise and fall of societies since early times. This course will focus on early civilizations, classical civilizations, and the development of modern nations.

### 31102 Geography and History of the World

Open to grades 9, 10

2 semesters, 1 credit per semester

Approximate cost per semester: \$5.63

Meets requirements: THD, AHD, Core 40, NCAA, GS

Students will learn how to use a geographic way of looking at the world. Students will be able to source, corroborate and contextualize a variety of primary sources and be asked to make applications to modern day issues. Major themes include the study of world religions and exploration and conquest. Imperialism, innovations, and revolutions will also be taught. Geography themes that will be explored include change over time, culture, and locations. Students will have a chance to complete research projects and make presentations. This course will focus on historical events for the period beginning in 1000 CE.

## JUNIORS

### 32302 United States History

Open to grade 11

2 semesters, 1 credit per semester

Approximate cost per semester: \$5.63

Meets requirements of: THD, AHD, Core 40, NCAA

This course builds upon concepts developed in previous studies of American History and emphasizes a detailed study of the development of our nation from the Civil War to the present. Students study the key events, people, groups, and movements in the late 19th –21st centuries, as they relate to life in the United States. Students are expected to develop skills of historical thinking that involve chronological thinking, comprehension, analysis, and interpretation, and research. Students will think like junior historians by being able to correctly source, corroborate and contextualize primary sources.

### 32300 AP United States History

Open to grade 11

2 semesters, 1 credit per semester

Approximate cost per semester: \$23.11

Meets requirements: THD, AHD, Core 40, NCAA

**Recommendation(s): Grade of B or better in World History and Civilization or Geography and History of the World; top 20% of sophomore class. A teacher's recommendation is strongly encouraged.**

This course is designed for students who wish to study American History in more depth and detail than is possible in 32302 - United States History. This challenging course follows the College Board Entrance Examination guidelines for Advanced Placement United States History and prepares students for intermediate and advanced college courses by making demands equivalent to those of a college course. Students will use sourcing, corroboration and contextualization skills to analyze and draw conclusions from primary sources. College credit is possible depending upon college and university requirements. It is an expectation of CNHS that students will take the College Board's AP US History exam in the spring.

## SENIORS

*(1 semester of Economics and 1 semester of U.S. Government are required.)*

### **36402 Economics**

**Open to grade 12**

**1 semester, 1 credit per semester**

**Available for Early College Credit (Dual Credit)**

**Approximate cost per semester: \$8.79**

**Meets requirements: THD, AHD, Core 40, NCAA**

This course examines the allocation of scarce resources and the economic reasoning used by people as consumers, producers, savers, investors, workers, voters, and as government agencies. It also examines economy as a whole, including investment, stock markets, the role of unions, and the national economy measure by the GDP.

### **36100 AP Economics - Micro & Macro Economics**

**Open to grade 12**

**2 semesters, 1 credit per semester**

**3 Approximate cost per semester: \$27.27**

**Meets requirements: THD, AHD, Core 40, NCAA**

**Two AP courses in one!** This course will follow College Board Entrance Examination guidelines and is offered for the college-bound student who needs a rigorous treatment comparable to a college freshman class. The first semester is devoted to the study of macroeconomics with a focus on how an open economy interacts with the rest of the world both through goods markets and financial markets and the implications for the foreign exchange market. The course shall explore foreign exchange markets and examine how the equilibrium exchange rate is determined. The second semester is devoted to the study of microeconomics with a focus on the concepts of opportunity costs and trade-offs. Students will be expected to take the AP Micro and Macro Economics exams at the end of the year for possible college credit depending upon college and university requirements.

### **36404 Economics (Standard Level)**

**Open to grade 12**

**1 semester, 1 credit per semester**

**Approximate cost per semester: \$10.39**

**Meets requirements: THD, AHD, Core 40, NCAA**

This course is designed to help the student know how to cope with managing his or her own finances. The course provides valuable help in teaching skills about career selection, interviews, job applications, budgeting, consumer purchasing and advertising, and the stock market.

### **35402 United States Government**

**Open to grade 12**

**1 semester, 1 credit per semester**

**Approximate cost per semester: \$10.12**

**Meets requirements: THD, AHD, Core 40, NCAA**

This course provides a framework for understanding the purposes, principles and practices of American government. Students are expected to understand their rights and responsibilities as citizens. Students learn to identify the roles of individuals and groups in the political process by discussing, evaluating, and defending positions on political issues using sound logic and evidence.

### **35100 AP Government & Politics: United States Comparative**

**Open to grade 12**

**1 semesters, 1 credit per semester**

**Approximate cost per semester: \$20.47**

**Meets requirements: THD, AHD, Core 40, NCAA**

The AP Government and Politics: United States Comparative course will follow the College Board Entrance Examination guidelines and is offered for the college bound student who needs a rigorous treatment equivalent to a college freshman level U.S. Government class. Topics covered will include the constitutional underpinnings of American government, political beliefs and behaviors, political parties, interest groups and the mass media. The in-depth study of the 3 branches of government, public policy, and the understanding of our civil rights and liberties will be included. Students will be expected to take the Advanced Placement U.S. Government and Politics: United States Comparative exam at the end of the school year for possible college credit.

### **35404 United States Government (Standard Level)**

**Open to grade 12**

**1 semester, 1 credit per semester**

**Approximate cost per semester: \$10.12**

**Meets requirements: THD, AHD, Core 40, NCAA**

This course is designed to help students become independent thinkers and conscientious citizens. Topics include the methods of public participation in policy making, citizenship rights and responsibilities, and the relationship between modern society and government.

## SOCIAL STUDIES ELECTIVES

### **31105 AP Human Geography**

**Open to grades 10, 11, 12**

**2 semesters, 1 credit per semester**

**Approximate cost per semester: \$22.26**

**Meets requirements: THD, AHD, Core 40, NCAA, GS**

This AP level course will follow the College Board Entrance Examination guidelines and is offered for the college bound student who needs a rigorous treatment equivalent to a college freshman course and has a serious interest in becoming more geo-literate, engaged in contemporary global issues and more multicultural in their viewpoints. You will develop skills to approach problems geographically, using maps and geospatial technologies, thinking critically and applying geographic concepts such as scale, region and diffusion among others. Students will be expected to take the AP exam at the end of the school year for possible credit.

### **37006 Sociology**

**Open to grades 10, 11, 12**

**1 semester, 1 credit per semester**

**Approximate cost per semester: \$12.56**

**Meets requirements: THD, AHD, Core 40, NCAA, GS**

Sociology provides students with the opportunity to study human social behavior from a group perspective. Topics of study include socialization, values and norms, deviance, stratification, families, education, and religion. Social problems such as poverty and discrimination are also explored. Projects revolve around the investigation of local service agencies and service learning. Many "hands-on" lessons will be utilized.

### **37004 Psychology**

**Open to grades 10, 11, 12**

**1 semester, 1 credit per semester**

**Approximate cost per semester: \$10.46**

**Meets requirements: THD, AHD, Core 40, NCAA, GS**

Psychology provides students the opportunity to explore the behaviors of individuals and groups. Areas of study include the scientific method, lifespan development, cognition, personality, assessment and mental health, and socio-cultural and biological bases of behavior. Major psychological theories and their methods will be researched. This course is "project" oriented.

### **37005 AP Psychology**

**Open to grades 11, 12**

**2 semesters, 1 credit per semester**

**Approximate Total Course Costs: \$22.98**

**Meets requirements: THD, AHD, Core 40, NCAA**

**Recommendations: Successful completion of all prior Social Studies courses.**

The AP Psychology course will follow College Board Entrance Examination guidelines and is offered for the college bound student who has a serious interest in human behavior and mental processes. 1st semester will include an investigation of psychology's history and research methods, biological bases of behavior, sensation and perception, states of consciousness, cognition and learning, and motivation and emotion. 2nd semester focuses on developmental psychology and personality theory, intelligence testing and individual differences, abnormal psychology and treatment of disorders, and social psychology. This course is taught at the college level. Students will learn to think critically and independently while advancing their skill sets in research & writing, reading & note-taking, problem solving, and test taking ability. Each semester includes guest presentations from community members with expertise in the various topics of study. Students were expected to take the AP Psychology exam in May. College credit is possible (depending on college & university requirements).



### 37001 Humanities

Open to grades 10, 11, 12

1 semester, 1 credit per semester

Available for Early College Credit (Dual Credit)

Approximate cost per semester: \$1.00

Meets requirements: THD, AHD, Core 40, GS

Prerequisite(s): Must have passed 31101 World History and Civilization or 31102 Geography and History of the World with a grade of C or better

Content drawn from human history, philosophy, the arts, religion, literature, and the state of human existence, including issues of cause and effect derived from disciplines that include: political science, linguistics, prejudice and discrimination, archeology, comparative religions, and the arts. Particular attention is given to the relevance of these applications in regard to the current conditions of life with student projects that depict an understanding of such disciplines.

### 37010 AP European History

Open to grades 10, 11, 12

1 semesters, 1 credit per semester

Approximate cost per semester: \$13.44

Meets requirements: THD, AHD, Core 40, NCAA, GS

This AP level course will follow the College Board Entrance Examination guidelines and is offered for the college bound student who needs a rigorous treatment equivalent to a college level European History class. The study of European history since 1450 introduces students to cultural, economic, political, and social developments that played a fundamental role in the shaping of the world in which we live. Students are expected to demonstrate knowledge of basic chronology, and of the major events and trends from approximately 1450 to the present. Students will be expected to take the AP European History exam at the end of the school year for possible college credit.

# HEALTH/PHYSICAL EDUCATION

To meet the PE requirement, students will complete one of the following options

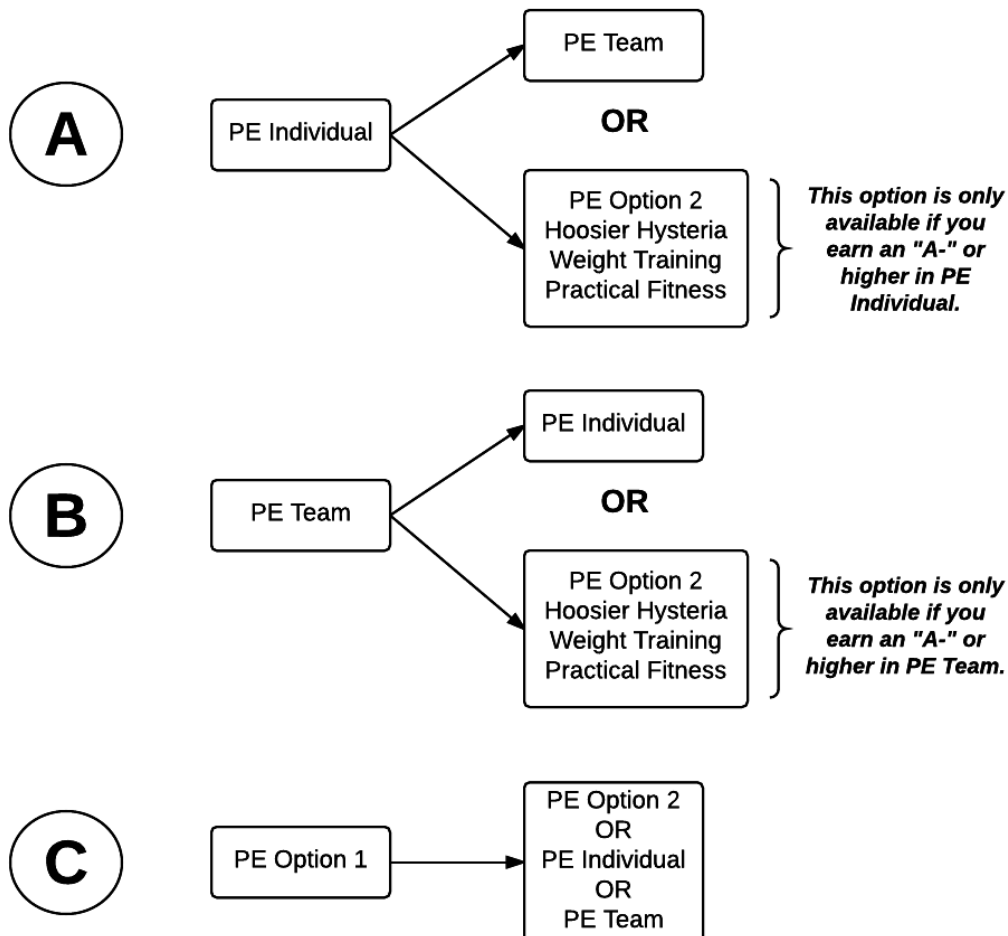

## 74301 Health Education

Open to grades 9,10,11,12

1 semester, 1 credit per semester

Approximate cost per semester: \$8.75

Meets requirements: AHD, Core 40

Health Education is a one-semester course that focuses on developing knowledge, concepts, skills, behaviors, and attitudes related to student health and well being. Topics of learning and discussion are: (1) Growth and Development; (2) Mental Health and Emotional Health; (3) Community and Environmental Health; (4) Nutrition; (5) Family Life; (6) Consumer Health; (7) Personal Health; (8) Alcohol, Tobacco and Other Drugs; (9) Intentional and Unintentional Injury; and (10) Health Promotion and Disease Prevention.

## 71102 PE Team Sports

Open to grades 9, 10, 11

1 semester, 1 credit per semester

Waiver available to qualifying applicants (see PE waiver procedures)

Approximate cost per semester: \$3.15

Meets requirements: AHD, Core 40

Prerequisite(s): Only one Basic PE class per semester

This is a one semester course that places an emphasis on health-related fitness and developing the skills and habits necessary for a lifetime of activity. An emphasis is placed on team sports, aerobic exercise, flexibility, aquatics, muscular strength, and muscular endurance. Students learn and participate in weight training, soccer, ultimate frisbee, volleyball, basketball, gatorball, softball and swimming.

## 71101 PE Individual Sports

Open to grades 9, 10, 11

1 semester, 1 credit per semester

Waiver available to qualifying applicants (see PE waiver procedures)

Approximate cost per semester: \$3.15

Meets requirements: AHD, Core 40

Prerequisite(s): Only 1 Basic PE Class per semester

This course provides students with opportunities to achieve and maintain a health-enhancing level of physical fitness and increase their knowledge of fitness concepts. A variety of technologies are used for personal fitness assessments.

Students participate in activities, including health related fitness activities, aerobic exercise, tennis, golf, archery, pickleball, badminton, table tennis, and aquatics.

## 71201/71202 PE Option

Open to grades 9, 10, 11, 12

1 semester, 1 credit per semester

Note: This course requires on-line capability as it is managed through the itsLearning.

### Enrollment Procedure:

1. Check the school website for qualifications and verify that you are eligible for the waiver program under the set guidelines (information found on BCSC home page, under Parent Info).
2. When scheduling for the next school year, make sure to sign up for the PE Option.
3. To finalize enrollment in the program, a student must submit a completed application form to the Counseling Center DURING the

first week of the waiver semester. **Note:** the application form must have BOTH the parent signature and the activity sponsor/coach signature. **REMINDER:** applications will not be accepted until the first week of the semester of enrollment and MUST be completed even if PE Option is listed on the student's schedule.

4. Once the application has been submitted and accepted, the student will receive verification of enrollment and further instructions for completion from the PE teacher of record.

## 77510 Advance PE: Hoosier Hysteria

Open to grades 10,11,12

1 semester, 1 credit per semester

Note: This course is possible second semester for grade 9.

Approximate cost per semester: \$3.15

Meets requirements: THD, AHD elective

Prerequisite(s): Have passed 71402 PE I (Team Sports), 72401 PE II (Individual sports) or have successfully waived PE 1 and/or 2.

Indiana is known for its love of basketball known as Hoosier Hysteria. This course will provide students the opportunity to learn basketball history, skills, rules, and conditioning. This course is intended for students who love the game of basketball. Class activities will include basketball drills, a variety of basketball related games, basket- ball conditioning, and scrimmaging.

## 77520/77521 Advanced PE: Weight Training & Conditioning

Open to grades 10,11,12

1 semester, 1 credit per semester

Note: This course is possible second semester for grade 9.

Approximate cost per semester: \$3.15

Meets requirements: THD, AHD elective

Prerequisite(s): Have passed 71402 PE I (Team Sports) AND 72401 PE II (Individual sports) or have successfully waived PE 1 and/or 2.

The course provides students the opportunity to learn and intensively train in fundamentals of weight training and speed, agility, quickness (SAQ). Weight room emphasis is placed on muscular hypertrophy (base building), muscular strength, peak strength and muscular flexibility. Movement emphasis is placed on improving straight line speed, lateral agility and foot quickness. The program focuses on athleticism and is not limited to, but is especially valuable for students in sports at North.

## 77511 Advanced PE: Practical Fitness

Open to Grade(s): 10, 11, 12

1 semester, 1 credit per semester

Approximate Total Course Cost: \$3.15

Meets requirements: Core 40 (Directed Elective or Elective), AHD, THD

Prerequisite(s): Have passed 71402 PE I (Team Sports) AND 72401 PE II (Individual sports) or have successfully waived PE 1 and/or 2.

This course is offered for those students interested in improving their personal fitness beyond required PE classes. The goal of this course is to create an awareness of a healthy lifestyle through exercise and nutrition. Students will take ownership of and responsibility for their fitness. Personal fitness goals will be set individually and worked toward during the semester via modern techniques, including but not limited to Pilates, aerobics, yoga, stretching, walking, jogging, Tae Bo, and Zumba. Practical (at home or at work/non-gym) ways to exercise, and topics related to health, lifetime fitness, and disease prevention will be studied.



# WORLD LANGUAGES

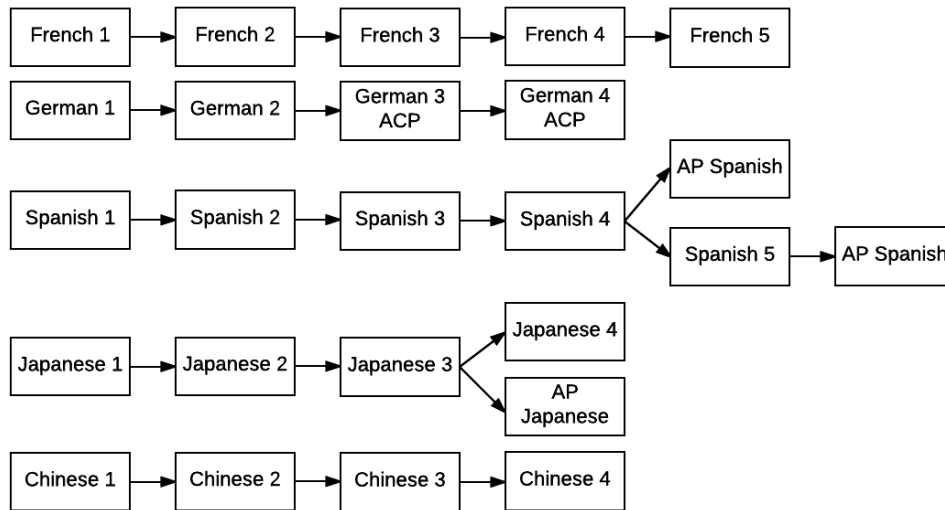

## CREDIT FOR 8TH GRADE WORLD LANGUAGE

World Language grades at 8th grade go with the student no matter what they are. These grades are to count in their GPA. Students who receive a C- or lower may elect to repeat the course and the higher grade will be honored.

### 61101 French 1

Open to grades 9,10,11,12

1 semesters, 1 credit per semester

Approximate cost per semester: \$15.62

Meets requirements: THD Direct Elective, AHD, Core 40, GS, NCAA

The focus of this level is on basic communication with learned phrases, simple questions and answers in the present tense, and an introduction to past narration. There is much emphasis on French pronunciation and intonation. Students often work in pairs or small groups for daily oral practice and to role-play real-life situations.

### 61202 French 2

Open to grades 9,10,11,12

2 semesters, 1 credit per semester

Approximate cost per semester: \$15.62

Meets requirements: THD Direct Elective, AHD, Core 40, GS, NCAA  
Prerequisite: 61101 French 1

In this level students review and expand on the basic communicative structures and vocabulary from Level 1. The primary focus is on narrating past events, orally and in writing; describing daily activities in more detail; engaging in longer communicative exchanges; and reading. Cultural focus is on the richness of the French speaking world. Paired oral work and role-playing are continued at this level. Students begin to focus more on paragraph writing.

### 61303 French 3

Open to grades 9,10,11,12

2 semesters, 1 credit per semester

Approximate cost per semester: \$15.62

Meets requirements: THD Direct Elective, AHD, Core 40, GS, NCAA  
Prerequisite(s): 61202 French 2

Students begin this level by reviewing the basic concepts of Levels 1 and 2. Students develop reading skills and cultural awareness of the French-speaking world through use of authentic regalia and magazine format readings. Special attention is given to the passé composé, imperfect, future, and conditional verb tenses.

### 61404 French 4

Open to grades 10,11,12

2 semesters, 1 credit per semester

Approximate cost per semester: \$16.57

66.97 Meets requirements: GS Prerequisite(s): 61303 French 3

This advanced level is designed for students who want to continue their French studies beyond the basic graduation requirements. This class is conducted in French. The format of the class is flexible to meet the needs and interests of the students. Since 4th and 5th year students are in the same class, the primary topics covered are on a two-year rotation.

### 61405 French 5

Open to grade 11,12

2 semesters, 1 credit per semester

Approximate cost per semester: \$16.57

Meets requirements: GS Prerequisite(s): 61404 French 4

Students will be able to complete the two-year sequence of study begun in Level 4. The same texts will be used as in Level 4. The class is conducted in French. This level provides students with additional time to hone their skills in preparation for SAT II, AP tests, and university placement tests, and greatly benefits students who intend to incorporate French in their career plans.

### 62101 German 1

Open to grades 9,10,11,12

2 semesters, 1 credit per semester

Approximate cost per semester: \$15.32

Meets requirements: THD Direct Elective, AHD, Core 40, GS, NCAA

Students begin their study of the language and culture of the German speaking countries. They acquire basic language skills through listening, speaking, reading, writing, and cultural activities. These activities may include short, guided conversations based on everyday situations, reading authentic materials (menus, train schedules, advertisements, etc.).

## **62202 German 2**

**Open to grades 9,10,11,12**

**2 semesters, 1 credit per semester**

**Approximate cost per semester: \$15.32**

**Meets requirements: THD Direct Elective, AHD, Core 40, GS, NCAA**

**Prerequisite(s): 62101 German 1**

Students continue their study of the German language and culture. They expand their vocabulary and grammar skills through practice in the five language skills. They converse on more topics, comprehend longer narratives, write longer passages, discuss current events and celebrate holidays.

## **62303 German 3 ACP**

**Open to grades 10,11,12**

**2 semesters, 1 credit per semester**

**Approximate cost per semester: \$13.21 for text and workbook. ACP tuition is \$100 for the year for students who want college credit. ACP is offered through IU.**

**Meets requirements: THD Direct Elective, AHD, Core 40, GS, NCAA**

**Prerequisite(s): 62202 German 2**

Students increase their proficiency in the language and culture of Germany. They expand their vocabulary and complete their study of grammar. The five language skills continue to be emphasized, but students will converse in depth (give explanations and reasons, tell stories, read short stories, poems, and write short essays).

## **62407 German 4 ACP**

**Open to grade 12**

**2 sem. 2 high school credits/6 hours college credit**

**Approximate required book rental cost: \$14.37**

**Approximate costs: \$150.00 (tuition) for students who want college credit (students who do not want college credit DO NOT PAY)**

**Approximate Total Course Cost: \$164.37 if students want credit and buy books themselves**

**Meets requirements of: Core 40 with AHD, GS**

**Prerequisite(s): 62404 German 3 ACP with a grade of C- or better**

German 4 ACP (Advanced College Project) is equivalent to G200 and G250 at Indiana University. Students who apply to Indiana University Advance College Project, pay tuition, and successfully complete the course will receive 6 hours of college credit that may be transferred to more than 500 universities. Students who do not wish to receive college credit may also take the class and receive the same level of instruction. By the end of the course, students will be able to read authentic texts and understand video segments on a variety of topics. Students will increase their ability to communicate thoughts in German--both orally and in writing--and have a stronger knowledge of German grammar. Students will learn about issues and problems in contemporary German-speaking countries.

## **64101 Spanish 1**

**Open to grades 9,10,11,12**

**2 semesters, 1 credit per semester**

**Approximate cost per semester: \$11.91**

**Meets requirements: THD Direct Elective, AHD, Core 40, GS, NCAA**

**Prerequisite(s): Must obtain a D- or above the first semester to continue on**

This course is an introduction to the five skills of reading writing, speaking, listening and culture. Vocabulary is introduced in context and practiced in numerous oral, written and listening exercises. Cultural material is presented in Spanish so that the students can acquire an up to-date awareness of Hispanic culture.

## **64202 Spanish 2**

**Open to grades 9,10,11,12**

**2 semesters, 1 credit per semester**

**Approximate cost per semester: \$11.91**

**Meets requirements: THD Direct Elective, AHD, Core 40, GS, NCAA**

**Prerequisite: 64101 Spanish 1 (passing both semesters)**

Spanish 2 is designed to improve the five skill proficiencies. The course begins with a review of the material previously covered in first year. Instructions and cultural readings are written in Spanish and help students work towards the goal of using Spanish in the class. Cultural material is integrated into the lessons so that students continually increase their knowledge of the Spanish speaking world.

## **64303 Spanish 3**

**Open to grades 9,10,11,12**

**2 semesters, 1 credit per semester**

**Approximate cost per semester: \$13.21**

**Meets requirements: THD Direct Elective, AHD, Core 40, GS, NCAA**

**Prerequisite(s): 64202 Spanish 2**

In Spanish 3 students continue the grammar sequence and polish skills previously acquired. There is an increased expectation for the student and teacher to use Spanish in the classroom. Support components of the text consist of videos, transparencies, tapes, CDs, workbooks, songs, CD-Rom practice and Internet resources.

## **64404 Spanish 4**

**Open to grades 10,11,12**

**2 semesters, 1 credit per semester**

**Approximate cost per semester: \$16.57**

**Meets requirements: THD Direct Elective, AHD, Core 40, GS, NCAA**

**Prerequisite(s): 64303 Spanish 3**

Reading skills are improved through culturally authentic selections focusing on an extensive examination of the Spanish speaking world. Self expression is emphasized through conversation and composition. Some activities include discussion of current events, personal experiences, letter writing, etc. Extensive vocabulary study covers a wide variety of topics.

## **64405 Spanish 5**

**Open to grades 11,12**

**2 semesters, 1 credit per semester**

**Approximate cost per semester: \$16.57**

**Meets requirements: THD Direct Elective, AHD, Core 40, GS, NCAA**

**Prerequisite(s): 64404 Spanish 4**

This course is intended as a transitional course to prepare students for the AP Spanish Language and Culture course. Students will participate in activities beyond the classroom including theater performances and community activities. Additionally, students will engage in conversations with native speakers in the community and initiate and participate in conversations on current or past events that are of significance in the foreign culture. Reading and writing skills are improved as students will analyze authentic texts and create short stories and poems. This course will also emphasize specific themes and skills necessary to prepare students for AP Spanish Language and Culture.

## **64406 AP Spanish Language & Culture**

**Open to grade 11,12**

**2 semesters, 1 credit per semester**

**Approximate cost per semester: \$15.47**

**Meets requirements of: AHD Elective, Core 40 Elective, GS**

**Prerequisite(s): 64404 Spanish 4**

The AP Spanish Language course is equivalent to a third-year college Spanish Language course. It is intended for students entering fifth-year Spanish. Through use of authentic materials and sources (i.e. movies, newspapers, podcasts and readings), students develop their Spanish language skills across three modes of communication: interpersonal, interpretive, and presentational. This course will prepare students to meaningfully engage in real world contexts with native Spanish speakers. It will also provide students with extensive vocabulary building (thematically) and recycling as well as informal and formal speaking and writing practice presented in the same format of the AP Language Exam. Spanish will be used almost exclusively in class by both students and teacher.

## **63101 Japanese 1**

**Open to grades 9,10,11,12**

**2 semesters, 1 credit per semester**

**Approximate cost per semester: \$7.14**

**Meets requirements: THD Direct Elective, AHD, Core 40, GS, NCAA**

Students will acquire basic vocabulary and communication skills in Japanese in students' familiar topics. Students will master 46 Hiragana characters and write and comprehend a short passages in the context of the topics above, using simple sentence patterns. Students will also learn about the country and the culture.

## **63202 Japanese 2**

**Open to grades 9,10,11,12**

**2 semesters, 1 credit per semester**

**Approximate cost per semester: \$12.50**

**Meets requirements: THD Direct Elective, AHD, Core 40, GS, NCAA**

**Prerequisite(s): 63101 Japanese 1**

Japanese 2 reviews the materials students studied in Japanese I. At this level, students reinforce and expand their knowledge of the vocabulary and grammar they have studied the previous year and will be able to engage more extended conversation in various situations in everyday life. Students will also practice how to use Japanese word processor and the Internet to facilitate development of their writing and reading skills.

## **63303 Japanese 3**

**Open to grades 10,11,12**

**2 semesters, 1 credit per semester**

**Approximate cost per semester: \$24.22**

**Meets requirements: THD Direct Elective, AHD, Core 40, GS, NCAA**

**Prerequisite(s): 63202 Japanese 2**

The use of the Japanese language in class is increased. Students will express themselves more fluently in the context of daily and school life. This course also provides students the opportunity to correspond with students in Japan. Writing skills will also be developed through weekly journals.

## **63404 Japanese 4**

**Open to grades 11,12**

**2 semesters, 1 credit per semester**

**Approximate cost per semester: \$24.22**

**Meets requirements: GS Prerequisite(s): 63303 Japanese 3**

This course emphasizes more extended oral and written communication by integrating the vocabulary and the sentence patterns that students already acquired in Japanese I through III. Students will also practice how to properly use formal and casual language styles. Writing skills will be developed through essay writing. By the end of the text- book, Adventures in Japanese 3, students will learn 219 Kanji characters.

## **63407 AP Japanese**

**Open to grades 11,12**

**2 semesters, 1 credit per semester**

**Approximate cost per semester: \$24.22**

**Meets requirements: GS**

**Prerequisite(s): Completion of Japanese 3 or 4 with a C+ or better**

This AP course is focused around creating meaningful opportunities for students to interact with the language, culture, and people of Japan by stressing the three modes of communication: interpersonal, interpretive, and presentational. Students will say more, write more, understand more, and feel more comfortable using the language with native speakers. This course will follow selected chapters in Nakama 2, a second-year college level textbook, while also delving into a wealth of authentic and semi-authentic supplemental materials including such sources as movies, traditional poetry, comic books, advertisements, and the Internet. Topics covered will delve into a range of disciplines including health, science, history, and cultural practices. Practice and assessments will come in a variety of forms including a number of projects as well as tests based on both the AP model and the Japanese Language Proficiency Exam.

## **65101 Chinese 1**

**Open to grades 9,10,11,12**

**2 semesters, 1 credit per semester**

**Approximate cost per semester: \$19.86**

**Meets requirements of: AHD Elective, Core 40 Elective, GS**

Students will respond to and give oral directions and commands and make routine requests in the classroom and in public places. They will be able to tell about daily routines and events. In addition they will learn to ask and answer simple questions and participate in brief guided conversations related to their needs and interests. There will be reading of isolated words and phrases in a situational context, such as menus, signs, and schedules and also comprehension of brief written directions and information. Short narrative texts on simple topics will be read. The writing of familiar words and phrases in appropriate contexts and responding in writing to various stimuli will be practiced. Students will also learn about holidays and customs, politics, economics, geography, and the history of Chinese-speaking nations.

## **65202 Chinese 2**

**Open to grades 10,11,12**

**2 semesters, 1 credit per semester**

**Approximate cost per semester: \$19.86**

**Meets requirements of: AHD Elective, Core 40 Elective, GS**

**Prerequisite(s): 65101 Chinese 1**

Students will be able to ask questions about everyday activities and talk about a wide variety of topics. They will also be able to retell an event or experience they have had. In addition, they will be able to use Chinese to ask for permission, ask and respond to offers of help, and to speak about their own personal choices in many situations. When reading about familiar topics in Chinese, they will be able to talk about the main idea. Also, they will read with correct intonation and expression. When writing characters, they will practice writing such things as postcards, personal notes, phone messages, and directions. They will learn how to do this in a culturally correct way. Along with language skills, students will learn more about the geography, history, and the politics of China and Chinese-speaking nations. Also, the arts (visual, architecture, literature, and music) will be discussed, using Chinese when possible. Finally, in a host/guest situation, students will know how to act and respond in a culturally proper manner.

## **65303 Chinese 3**

**Open to grades 10, 11, 12**

**2 semesters, 1 credit per semester**

**Approximate cost per semester: \$ 21.93**

**Meets requirements: AHD Elective, Core 40 Elective, GS**

**Prerequisite(s): 65202 Chinese 2**

In a variety of social situations, students will express their desires and opinions, including while traveling. Reading and summarizing from a variety of authentic materials such as advertisements, newspapers, magazines and personal correspondence will be carried out. Aspects of the culture such as historical, political, value systems, arts, music and literature will be studied and discussed in Chinese.

## **65404 Chinese 4**

**Open to grades 11, 12**

**2 semesters, 1 credit per semester**

**Approximate cost per semester: \$ 21.93**

**Meets requirements: GS**

**Prerequisites: Chinese 3**

Students use previously learned vocabulary to create new language and guess meaning. Students will continue to develop understanding of Chinese-speaking culture and will also learn more in-depth cultural, historical and art aspects of Chinese culture. Current trends and changes in Chinese-speaking nations will also be examined. Increased use of characters and Mandarin speaking in class will be required.

# JOURNALISM

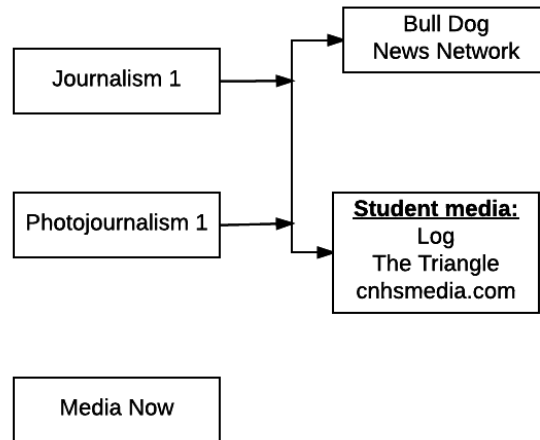

## 06111 Journalism 1

Open to grades 9,10,11

2 semesters, 1 credit per semester

Approximate cost per semester: \$20.34

Meets requirements: AHD Elective, THD Elective, Core 40, GS

Looking to write, design or take photos for North's award-winning newsmagazine, yearbook and other media? This is the class that prepares you by covering the basics, including interviewing and fact-gathering, writing news, features and sports, and gaining a foundation of journalism law and ethics. You will maintain a digital portfolio for which you will write, take photographs, design pages, edit, and design advertising. This course is a prerequisite for school media work.

## 06121 Photojournalism 1

Open to grades 9,10,11

2 semesters, 1 credit per semester

Approximate cost per semester: \$1.00

Meets requirements: AHD Elective, THD Elective, Core 40, GS

**Note: Students must have their own digital camera and must have 10 blank CDs or 2GB memory stick.**

For students interested in photojournalism who are responsible and ethical, this yearlong course offers students training in the basics of digital photography, camera handling and photo composition. In preparation for a staff, students will study

Adobe Photoshop and will also learn to operate their digital cameras beyond the auto setting. Photo assignments are designed for use by North's national award-winning publications. Students will be required to attend North activities beyond the classroom to successfully complete photo assignments. This course is a prerequisite for school media work.

## 06131 Media Now

Open to grades 10, 11, 12

1 semester, 1 credit per semester

Approximate course cost: \$1.00

Meets requirements of: AHD Elective, Core 40, GS

This elective course focuses on the role of media in shaping our perception of the world. Students will look at how media cover politics, sports, celebrities, conflict and new trends. This course will also emphasize new technology (blogs, wikis, websites, podcasts) used in shaping today's media.

### CNHS Media

Student media staff members often are required to spend several before and after school hours to prepare properly for the following classes.

## 06311 Student Publications - Log

Open to grades 10,11,12

1 semesters, 1 credit per semester

Approximate cost per semester: \$1.00

Meets requirements: AHD Elective, THD Elective, Core 40, GS

**Prerequisite(s): 06111 Journalism 1; 06121 Photojournalism 1; T52101 Introduction to Communications; formal application required for staff positions.**

This is the laboratory class which produces North's national award-winning yearbook, Log. Emphasis is on developing skills in interviewing, polling, writing, layout, business management, photography and digital production procedures employed in producing the yearbook. Staffers also sell advertising as a requirement of the course.

## 06321 Student Publications - The Triangle

Open to grades 10,11,12

2 semesters, 1 credit per semester

Approximate cost per semester: \$1.00

Meets requirements: AHD Elective, THD Elective, Core 40, GS

**Prerequisite(s): 006111 Journalism 1; 06121 Photojournalism 1; T52101 Introduction to Communications; formal application required for staff positions**

This is the laboratory class which writes, designs and digitally produces North's nationally-recognized school newsmagazine, The Triangle. The staff works in conjunction with the staff of cnhsmedia.com, crossing platforms for variety in storytelling. Staffers also sell advertising as a course requirement.

## 06331 Student Publications - cnhsmedia.com

Open to grades 10,11,12

2 semesters, 1 credit each semester

Approximate cost per semester: \$1.00

Meets requirements: AHD Elective, THD Elective, Core 40, GS

**Prerequisite(s): 006111 Journalism 1-2; 06121 Photojournalism 1; T52101 Introduction to Communications; formal application required for staff positions**

This is a laboratory class covering several public relations project areas which may vary as services are needed by North students, staff and community. The staff produces North's national award-winning web site [www.cnhsmedia.com](http://www.cnhsmedia.com). They write, design infographics and take pictures, updating the site weekly. The staff also uses social media sites Facebook and Twitter for breaking news. The staff works in conjunction with the staff of The Triangle, crossing platforms for variety in storytelling. Staffers also sell advertising as a course requirement.



**T52612 Radio and Television I: BNN**

**T52622 Radio and Television II: BNN**

Open to grades 9, 10, 11, 12

2 semesters, 2 credits per semester

Approximate cost per semester: Fees to be determined Meets requirements: THD, AHD, Core 40

Prerequisite(s): (Introduction to Communications, Journalism 1), application, interview and portfolio required for crew positions.

**Note: Student crew members are often required to spend several hours before and after-school.**

This is the laboratory class that produces North's national award-winning daily announcements and monthly magazine programs using digital video technology. Emphasis is on interviewing, writing with a storytelling focus, camera operation, digital video and audio editing and graphics. Students on crew will also serve as peer mentors to Beginning Multimedia students.

# VISUAL ARTS

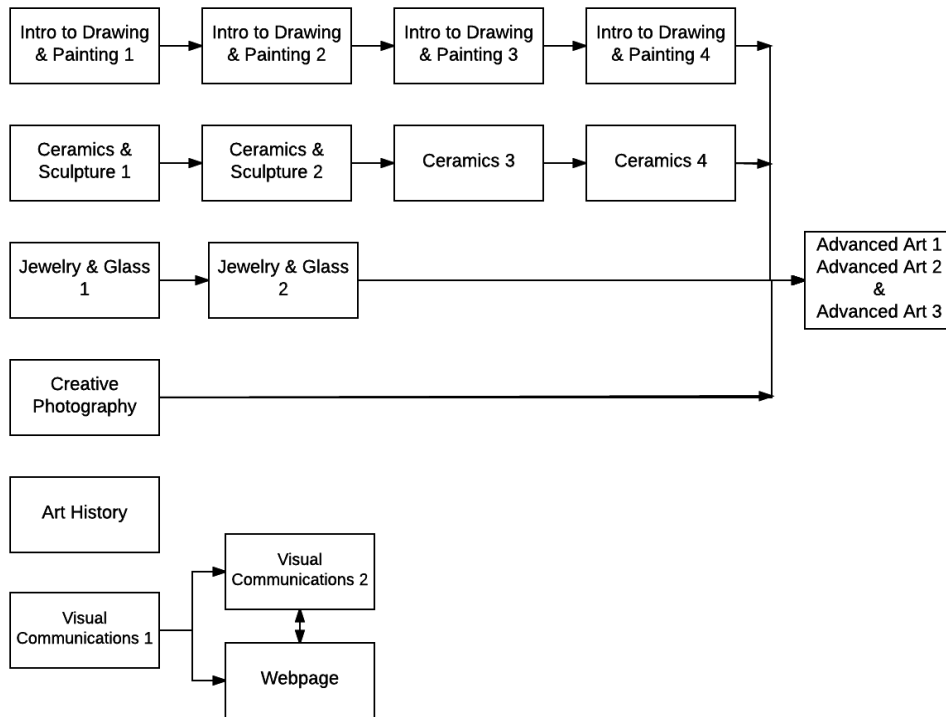

**40000 Art History**

Open to grades 9,10,11,12

1 semester, 1 credit per semester

Approximate cost per semester: \$11.25

Meets requirements of: AHD, Core 40

Students engage in learning experiences that encompass art history, art criticism and aesthetics. It begins as a chronological survey of painting, sculpture and architecture as they reflect the cultures in which they are produced. Students use technology such as the Internet, Powerpoint, Adobe PhotoShop, and writing programs to learn about and to create historically relevant documents, presentations, games and visual images. Students need not be proficient at producing art to be successful.

**40051 Jewelry and Glass 1**

Open to grades 9, 10, 11, 12

1 semester, 1 credit per semester

Approximate Total Course Cost: \$25.00

Meets requirements: Core 40, AHD

This jewelry course includes studio instruction and students creating their own jewelry pieces. This course includes studio instruction and students creating their own jewelry and glass pieces. Students will work with wire, make chains and jump rings, and create beaded jewelry, learn about joining methods, layout and finishing, and experiment with jewelry and glass techniques. No previous experience is required.

**40052 Jewelry and Glass 2**

Open to grades 9, 10, 11, 12

1 semester, 1 credit per semester

Approximate cost per semester: \$35.00

Meets requirements: AHD, Core 40

**Prerequisite: Completion of Jewelry and Glass 1 with a grade of C or above.**

This is a continuation of Jewelry and Glass 1 with emphasis on more advanced jewelry-making and glass techniques. Students apply jewelry design and fabrication techniques including sawing, piercing, filing, soldering, and knitting and crocheting wire and learn to work with enamel, metal, leather, plastic, wood and resin. Students study various glass-making methods: fusing, slumping and advanced lampwork techniques.

**40011 Introduction to Drawing and Painting 1**

Open to grades 9, 10, 11, 12

1 semester, 1 credit per semester

Approximate cost per semester: \$15.00

Meets requirements: AHD, Core 40

Introduction to Drawing and Painting 1 will encourage an understanding and appreciation of art through the study of the elements and principles of design. Students build skills in drawing, painting and design and will think about their work, explore art history, work individually and in groups, and find connections to other areas of study.

#### **40042 Drawing and Painting 2**

**Open to grades 9, 10, 11, 12**

**1 semester, 1 credit per semester**

**Approximate cost per semester: \$27.00**

**Meets requirements: AHD, Core 40**

**Prerequisite: Completion of Introduction to Drawing and Painting 1 with a grade of C or above.**

This course further develops concepts introduced in Drawing and Painting 1 as well as provides a deeper understanding of the elements and principles of design. Students will be introduced to new drawing and painting techniques and media. They will create drawings utilizing processes such as sketching, rendering, contour, gesture, and perspective drawing as well as experience sequential learning that encompasses various painting techniques. Students will work individually and in groups, reflect upon the outcome of their experience and explore historical connections.

#### **40043 Drawing and Painting 3**

**Open to grades 10, 11, 12**

**1 semester, 1 credit per semester**

**Approximate cost per semester: \$27.00**

**Meets requirements: AHD, Core 40**

**Prerequisite: Completion of Drawing and Painting 1 & 2 with a grade of C or above.**

Drawing and Painting 3 is a continuation of Drawing and Painting 2. It is an advanced level of drawing and painting that explores various levels techniques and media, with special emphasis on creativity. Students will explore learning experiences that encompass art history, art criticism, aesthetics, and production. They will study various drawing and painting styles with the emphasis on developing a personal style that expresses knowledge of color, drawing and painting skills and composition.

#### **40044 Drawing and Painting 4**

**Open to grades 10, 11, 12**

**1 semester, 1 credit per semester**

**Approximate Total Course Cost: \$27.00**

**Meets requirements: Core 40, AHD**

**Prerequisite(s): Completion of Drawing and Painting 1, 2, & 3 with a grade of C or above.**

This course is a continuation of Drawing and Painting 3 with a focus on figure drawing and painting. Students will explore learning experiences that encompass art history, art criticism, aesthetics, and production. They will study various drawing and painting styles throughout history that emphasize figure drawing and painting.

#### **40641 Visual Communication 1**

**Open to grades 10, 11, 12**

**1 semester, 1 credit per semester**

**Approximate cost per semester: \$12.00**

**Meets requirements: AHD, Core 40**

Visual Communication 1 teaches students to express ideas and information using type, illustration, and graphic design. The computer and the Adobe Suite will be the main tools students use. Students should be aware however, that while the computer is the main tool for this class, the ultimate goal is learning good design. Students will create various kinds of designs, think about the results of their work, and explore connections to art history.

#### **40642 Visual Communication 2**

**Open to grades 10, 11, 12**

**1 semester, 1 credit per semester**

**Approximate cost per semester: \$12.00**

**Meets requirements: AHD, Core 40**

**Prerequisite(s): 40641 Visual Communication 1 with a grade of C or above**

Visual Communication 2 continues to reinforce concepts and skills taught in Visual Communication 1. Students create various types of graphic designs, poster designs, and a short animation using the following Adobe programs: Illustrator, Photoshop, InDesign, and Premiere.

#### **40650 Creative Photography**

**Open to grades 10, 11, 12**

**1 semester, 1 credit per semester**

**Approximate cost per semester: \$15.00**

**Meets requirements: AHD, Core 40**

**Prerequisite(s): Students must provide their own digital camera and blank CDs or 2GB memory stick.**

Students learn about modern camera systems and digital imaging using Adobe Photoshop. Learning how to take and manipulate meaningful photographs by adjusting settings such as aperture, ISO and shutter speed will be a primary activity of this class. All assignments and experiences are designed to help students develop an appreciation for the photographic process and how the resultant images can affect us as individuals and as a society. As a recommendation to take this course, students are encouraged to have a DSLR CAMERA (students with iPhones, point and shoot cameras, CoolPix, and other basic cameras will need to complete modified assignments, as they will not be able to adjust aperture, ISO, and shutter speed.)

#### **40541 Webpage**

**Open to grades 10, 11, 12**

**1 semester, 1 credit per semester**

**Approximate cost per semester: \$12.00**

**Meets requirements: AHD, Core 40**

**Prerequisite: 40641 Visual Communication 1 with a grade of C or above**

This course teaches students how to create effective websites using Netscape Composer and Macromedia Dreamweaver. Students also receive basic instruction in Adobe Photoshop and Adobe Illustrator, programs they use to create original graphics for inclusion in their webpages. Students create various types of graphic designs, reflect upon the outcome of their experiences, explore historical connections and make presentations about their progress at regular intervals.

#### **40001 Ceramics & Sculpture 1**

**Open to grades 9, 10, 11, 12**

**1 semester, 1 credit per semester**

**Approximate cost per semester: \$18.00**

**Meets requirements: AHD, Core 40**

Students learn the basics of handbuilding as well as learning all about the physical properties of creating vessel forms with clay. Students learn techniques with pinch, coil and slab in this semester class. Form and design is emphasized, and students learn the entire process of creating a ceramic from workable plastic clay to a finished-fired glazed piece. In addition, students create quality sculptures and study issues concerning sculpting including design, art history, art criticism, and production. Students create geometric and organic sculptures using the subtractive and additive techniques of carving, modeling, construction, and assemblage using materials such as wire, paper mache pulp, soapstone and plaster. Students think about the meaning of their work including its connection to art history.

#### **40002 Ceramics & Sculpture 2**

**Open to grades 9, 10, 11, 12**

**1 semester, 1 credit per semester**

**Approximate cost per semester: \$18.00**

**Meets requirements: AHD, Core 40**

**Prerequisite: 40001 Ceramics & Sculpture 1 with a grade of C or above**

Ceramics & Sculpture 2 is for those students who are interested in furthering their knowledge, creativity and tactile ability with clay forms. This course involves and demands a higher level of achievement and responsibility. Students continue to enhance their handbuilding skills with various ceramic techniques. Project responsibility and choice will be directed by the instructor. Students create quality sculptures and study issues concerning sculpting including design, art history, art criticism, and production. In addition, students create realistic and abstract sculptures using materials such as wood, foam board, wire and patinas. Students think about the meaning of their work including its connection to art history.

### **40003 Ceramics 3**

**Open to grades 10, 11, 12**

**1 semester, 1 credit per semester**

**Approximate cost per semester: \$18.00**

**Meets requirements: AHD, Core 40**

**Prerequisite(s): 40002 Ceramics & Sculpture 2 with a grade of C or above**

Within this continuation of Ceramics & Sculpture 2, students will engage in sequential learning experiences that encompass art criticism, aesthetics, and production. Students continue to create works of art in clay utilizing the processes of hand building, molds, wheel throwing, slip and glaze techniques, and the firing processes. Students will reflect upon the historical, cultural, and functional aspects of their ceramic forms.

### **40004 Ceramics 4**

**Open to grades 10, 11, 12**

**1 semester, 1 credit per semester**

**Approximate Total Course Cost: \$20.00**

**Meets requirements: Core 40, AHD**

**Prerequisite(s): Ceramics 3 with a grade of C or above**

This course is for the serious, self-motivated student, who wants advanced studio time for creating ceramic art. Students will follow a curriculum of both assigned problems and independent studies. Students will develop more in-depth skills in hand building, decorating, glazing, and wheel throwing, reflect upon the outcomes of their work, and explore career options.

### **40751 Advanced Art 1**

**Open to grades 11, 12**

**1 semester, 1 credit per semester**

**Approximate cost per semester: \$40.00**

**Meets requirements: AHD, Core 40**

**Prerequisite: C average through all preceding levels (4 semesters of Drawing & Painting or Ceramics; 2 semesters of Jewelry & Glass; 1 semester of Creative Photography).**

Art Advanced 1 is for the serious, self-motivated student, who wants advanced studio time for creating art in drawing and painting, jewelry,

creative photography, or ceramics. Students follow a curriculum of both assigned problems and independent studies. Students develop more in-depth skills in their chosen media, reflect upon the outcomes of their work, explore historical connections, This class may be taken multiple times. Students must specify to their counselor which media they are working in so proper scheduling may be done: Drawing and Painting; Jewelry and Glass; Creative Photography; Ceramics.

### **40752 Advanced Art 2**

**Open to grades 11, 12**

**1 semester, 1 credit per semester**

**Approximate cost per semester: \$40.00**

**Meets requirements: AHD, Core 40 Prerequisite: 40751 Advanced Art 1**

A continuation of Art Advanced 1, this course is for the serious, self-motivated student, who wants advanced studio time for creating art or building a college portfolio. Students follow a curriculum of both assigned problems and independent studies. Students develop more in-depth skills in their chosen media, reflect upon the outcomes of their work, explore historical connections, This class may be taken multiple times. Students must specify to their counselor which media they are working in so proper scheduling may be done: Drawing and Painting; Jewelry and Glass; Creative Photography; Ceramics.

### **40753 Advanced Art 3**

**Open to grade 12**

**1 semester, 1 credit per semester**

**Approximate cost per semester: \$40.00**

**Meets requirements of: AHD**

**Prerequisite(s): 40751 Advanced Art 1 and 40752 Advanced Art 2 with a grade of a B or above**

A continuation of Art Advanced 2, this course is for the serious, self-motivated student, who wants advanced studio time for creating art or building a college portfolio. Students follow a curriculum of both assigned problems and independent studies.

Students develop more in-depth skills in their chosen media, reflect upon the outcomes of their work, explore historical connections, This class may be taken multiple times. Students must specify to their counselor which media they are working in so proper scheduling may be done: Drawing and Painting; Jewelry and Glass; Creative Photography; Ceramics.

Creating  
Imagining  
Innovating



# INSTRUMENTAL MUSIC

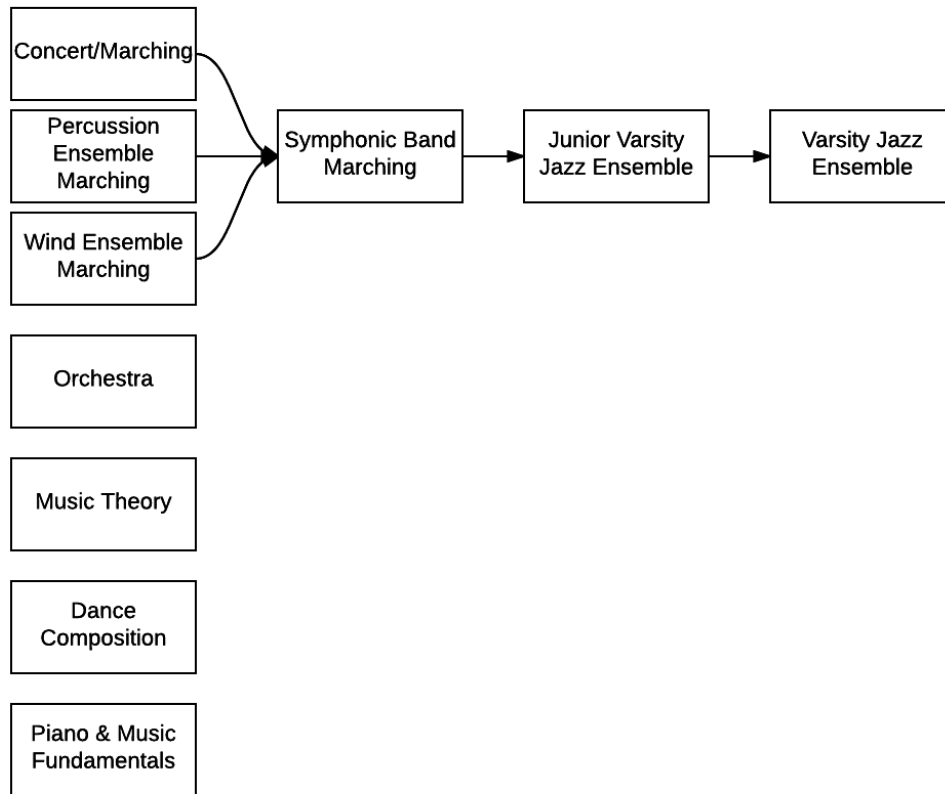

## 42003 Concert March

Open to grades 9, 10, 11, 12

2 semesters, 1 credit per semester

Approximate cost per semester: \$20.00

Meets requirements: AHD, GS

Prerequisite(s): Previous instrumental instruction

The first nine weeks, Wind Ensemble, Symphonic March and Concert March Bands form the Marching Band and perform at contests, festivals, parades and varsity football games. Ensemble & solo activities are designed to develop elements of musicianship including tone production, technical skills, intonation, music reading skills, listening skills, analyzing music and studying important styles of literature. Students are required to participate in outside rehearsals and performances.

## 42001 Symphonic March

Open to grades 10,11,12

2 semesters, 1 credit per semester

Approximate cost per semester: \$20.00

Meets requirements: AHD, GS

Prerequisite(s): Concert March

The first nine weeks, Wind Ensemble, Symphonic March and Concert March Bands form the Marching Band and perform at contests, festivals, parades, and varsity football games. Ensemble and solo activities are designed to develop elements of musicianship including tone production, technical skills, intonation, music reading skills, listening skills, analyzing music, and studying important styles of literature. Experiences include improvising, conducting, playing by ear, sight-reading. Students are required to participate in outside the school day rehearsals and performances. Evaluation of music and music performances is included.

## 42002 Wind Ensemble March

Open to grades 10, 11, 12

2 semesters, 1 credit per semester

Approximate cost per semester: \$20.00

Meets requirements: AHD, GS

Prerequisite(s): Concert and/or Symphonic Band

The first nine weeks, Wind Ensemble, Symphonic March and Concert March Bands form the Marching Band and perform at contests, festivals, parades, and varsity football games. Ensemble and solo activities are designed to develop elements of musicianship including tone production, technical skills, intonation, music reading skills, listening skills, analyzing music and studying important styles of literature. Experiences include improvising, conducting, playing by ear, sight-reading. Students are required to participate in outside the school day rehearsals and performances. Repertoire will be of the highest caliber.

## 42004 Percussion Ensemble

Open to grades 9, 10, 11, 12

1 semester, 1 credit per semester

Approximate cost per semester: \$20.00

Meets requirements: AHD, GS

Prerequisite(s): Audition/previous instrumental instruction; Must enroll in one of the concert bands 2nd sem.

Percussion ensemble provides students with a comprehensive study of music, focusing on performance techniques unique to percussion. Students are required to participate in all outside rehearsals and performances. Evaluation of music and music performances is included. The first semester, all percussion students from the band classes will meet. The Percussion Ensemble along with Wind Ensemble, Symphonic March and Concert March Bands form the Marching Band and will perform at contests, festivals, parades and varsity football games.

### 42321 Junior Varsity Jazz Band

Open to grades 9, 10, 11, 12

2 semesters, 1 credit per semester

Approximate cost per semester: \$10.00

Meets requirements: AHD, GS

Prerequisite(s): Must be enrolled in a band or orchestra class

Students will develop musicianship and specific performance skills through group and individual settings for the study and performance of varied styles of instrumental jazz. Students develop creative skills through improvisation, composition, arranging, performing, listening and analyzing. Students must also be receiving instruction in Wind Ensemble, Symphonic Band, Concert Band or String Orchestra. Jazz Ensemble

### 42322 Varsity Jazz Ensemble

Open to grades 10, 11, 12

2 semesters, 1 credit per semester

Approximate cost per semester: \$10.00

Meets requirements: AHD, GS

Prerequisite(s): Audition and must be enrolled in a band or orchestra class

Students in this course develop musicianship and specific performance skills through group and individual settings for the study and performance of varied styles of instrumental jazz. Students develop creative skills through improvisation, composition, arranging, performing, listening, and analyzing. Students are required to participate in a limited number of outside rehearsals and performances. Student participants must also be receiving instruction in Wind Ensemble, Symphonic Band, Concert Band or String Orchestra, and must audition for instructors.

### 42021 String Orchestra

Open to grades 9, 10, 11, 12

2 semesters, 1 credit per semester

Approximate cost per semester: \$20.00

Meets requirements: AHD, GS

Prerequisite(s): Must have experience on violin, viola, cello or string bass

Students receive a balanced comprehensive study of music through the string/full orchestra. Ensemble and solo activities are designed to develop elements of musicianship including tone production, technical skills, intonation, music reading skills, listening skills, analyzing music, and studying important styles of literature. Evaluation of music and music performances is included. Experiences include improvising, conducting, playing by ear, and sight-reading. Students are required to participate in a limited number of outside rehearsals and performances.

### 42335 Music Theory

Open to grades 10, 11, 12

2 semesters, 1 credit per semester

Approximate cost per semester: \$119.38

Meets requirements: AHD, GS

Students develop skills in the analysis of music and theoretical concepts. Students develop ear training and dictation skills, compose works that illustrate mastered concepts, understand harmonic structures and analysis, understand modes and scales, study a variety of musical styles, study traditional and nontraditional music notation and sound sources as tools for musical composition, and receive instruction in other basic elements of music. Basic music reading skills are necessary.

### 44002 Dance Composition/Performance

Open to grades 9, 10, 11, 12

1 semester, 1 credit per semester

Approximate cost per semester: \$20.00

Meets requirements: AHD, GS Prerequisite(s): Audition

This course is open to students interested in performing in Color Guard with marching band, as well as throughout the winter. Attendance at performances is required. Learning activities/experiences develop students' ability to understand the body's capabilities and potential; understand techniques of dance; understand varied styles; develop listening, comprehension and memorization skills; use simple to complex and compound dance patterns with props and equipment such as flags, sabers and rifles; identify and use appropriate terminology related to style and technique; and understand musical phrasing, rhythmic structures and meters.

### 41000 Piano and Music Fundamentals

Open to grades 9, 10, 11, 12

2 semesters, 1 credit per semester

Approximate cost per semester: \$40.00

Meets requirements: AHD, THD

Students will learn to play melodic, rhythmic and harmonic patterns on electronic keyboards. They will learn and practice the piano each day. Students will also develop keyboard specific music reading skills and notation of scales and chords in a variety of keys. This is a beginner class open to all grade levels. Students will be more successful in vocal and instrumental sight-reading skills by using their knowledge from piano keyboarding. It is a concrete learning style that promotes connection between note reading, processing and producing quality vocal and instrumental music. Students who plan to pursue a career in music will need piano and music fundamental knowledge to be placed in a higher learning music school.

# VOCAL MUSIC

These courses require an audition.

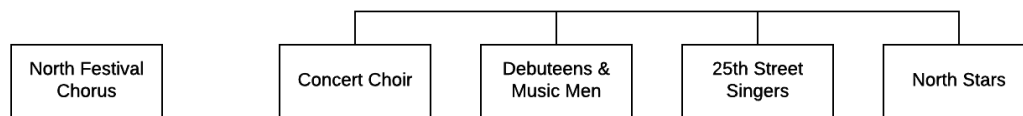

### 41010 North Festival Chorus

Open to grades 9, 10, 11, 12

2 semesters, 1 credit per semester

Approximate cost per semester: \$5.00

Meets requirements: AHD, GS

This choir is open to any beginner or intermediate singer. Choral repertoire will be from different styles/eras of music and will be developmentally appropriate. Emphasis will be placed on sight-reading, critical listening skills, and vocal technique. There are three (3) required concerts in the evening at school.

### 41001 Concert Choir

Open to grades 9, 10, 11, 12

2 semesters, 1 credit per semester

Approximate cost per semester: \$5.00

Meets requirements: AHD, GS

Prerequisite(s): Auditions held early 2nd semester for following year

This choir is open to 9-12 graders who meet the audition criteria. The choral repertoire is of the highest caliber, including a variety of music. Sight-reading, critical listening skills, and a cappella singing are stressed. Students are required to perform in at least three (3) concerts during the year.

**41211 25th Street Singers****Open to grades 10, 11, 12****2 semesters, 1 credit per semester****Approximate cost per semester: \$5.00 Meets requirements: AHD, GS****Prerequisite(s): Auditions will be held early in the 2nd semester for the following year**

Students in this course study sight-reading, harmonic blending, and solo singing as related to the stylistic elements of vocal jazz. Students develop their creative skills through improvisation, performing, listening, and analyzing. There are three (3) required concerts and various performing/competing opportunities.

**41301 Debutees & Music Men****Open to grades 10, 11, 12****2 semesters, 1 credit per semester****Approximate cost per semester: \$5.00 Meets requirements: AHD, GS****Prerequisite(s): Auditions will be held early in the 2nd semester for the following year**

This mixed chorus develops musicianship and specific performance skills through ensemble and solo singing with an emphasis on choreographed performances. The repertoire is of the highest caliber.

Well-balanced harmonic blend, a cappella singing, and good vocal technique are stressed. There are three (3) required concerts and various performing/competing opportunities.

**41201 North Stars****Open to grades 10, 11, 12****2 semesters, 1 credit per semester****Approximate cost per semester: \$5.00****Meets requirements: AHD, GS****Prerequisite(s): Auditions will be held early in the 2nd semester for the following year**

This chorus develops musicianship through ensemble and solo singing with an emphasis on choreographed performances. The repertoire is of the highest caliber. Well-balanced harmonic blend and good vocal technique are stressed. There are three (3) required concerts and various performing/competing opportunities.

# BUSINESS

How to earn a Technical Honors diploma in Business:

Minimum 6 credits

Recommended courses:

<b>Digital Applications &amp; Responsibility</b> (year long)  <i>Microsoft Office Specialist (MOS) certification available</i>	<b>Introduction to Accounting</b> (year long)	<b>Personal Financial Responsibility</b> (1 semester)	<b>Business Law and Ethics</b> (1 semester)
---	--	--	--

**To enhance skills, career and college readiness, add any of the following courses in grades 10-12:**

Specialty	Courses	Careers
Finance	<b>Advanced Accounting</b> (Counts as Quantitative Reasoning course) Global Economics	Bookkeeping, Accounting Clerk, Finance Manager
Management	Introduction to Business 1 and 2 <b>Principles of Business Management</b>	Entrepreneur, Human Resources Manager, Manager (general) and supervision
Marketing	<b>Principles of Marketing</b> Sports and Entertainment Marketing	Marketing Manager

**T1000 Preparing for College and Careers****Open to grade 9****1 semester, 1 credit per sem.****Approximate cost per semester: \$0.00****Meets requirements: THD, AHD, Core 40 (Directed Elective or Elective), GS****Note: Required for high school graduation.**

Students in this class address the knowledge, skills, and behaviors all students need to be prepared for success in college, career, and life. The focus is the impact of to-day's choices on tomorrow's possibilities. Topics addressed include 21st century life and career skills, higher order thinking, communication, leadership, personal finances, interests, values, and goals.

**T1161 Career Information and Exploration****Open to grade 12****1 semester, 1 credit per sem.****Approximate cost per semester: \$ 0.00****Meets requirements: THD, AHD, Core 40 (Directed Elective or Elective)**

Students develop organization skills and a plan to complete the Senior Project by writing a proposal outline, selecting a mentor, working with a mentor, following through on the project, and putting a portfolio together. Students are monitored to make sure the service learning and job shadowing components have been completed. Students develop skills in decision-making, time management, and speech preparation including dress, voice, body language, and use of effective visuals. Students also develop a professional resume, explore college & career opportunities and requirements, and complete multiple self-assessments using Naviance.

### **T1011 Introduction to Business 1**

**Open to grades 9, 10, 11**

**1 semester, 1 credit per sem.**

**Approximate cost per semester: \$8.58**

**Meets requirements: THD, AHD, Core 40 (Directed Elective or Elective)**

### **T1021 Introduction to Business 2**

**Open to grades 9, 10, 11**

**1 semester, 1 credit per sem.**

**Approximate cost per semester: \$8.58**

Meets requirements: THD, AHD, Core 40 (Directed Elective or Elective)  
Students in this class are introduced to the world of business, including the concepts, functions, and skills required for meeting the challenges of operating a business in the twenty-first century on a local, national, and international scale. This is a beginning course for students who might be interested in business as a career. Students may take this course for one semester or a full year. The course briefly covers a variety of topics such as personal finance, economics, marketing, human resources, accounting and small business ownership. Students leave the course prepared for future business classes and with a basic business understanding.

### **T1111 Information Communications & Technology I**

**Open to grades 9, 10, 11, 12**

**1 semester, 1 credit per semester**

**Approximate cost per semester: \$29.82**

**Meets requirements: THD, AHD Core 40 (Directed Elective or Elective), NCAA**

This course provides the student an opportunity to become proficient in the Microsoft software programs that include: Word, Excel, and PowerPoint. In the class students will learn to use these programs efficiently and thoroughly. This is an excellent course for those needing basic computer skills expected by employers and used in college.

### **T1121 Information Communications & Technology II**

**Open to grades 9, 10, 11, 12**

**1 semester, 1 credit per sem.**

**Approximate cost per semester: \$29.82**

**Meets requirements: THD, AHD, Core 40 (Directed Elective or Elective)**

**Dual Credit: Ivy Tech Community College**

**Aligned With: Indiana Core Transfer Library course Introduction to Microcomputers**

**Prerequisite(s): 51111 Information Communications and Technology I**

This is a comprehensive course designed for advanced users allowing them to become proficient in Microsoft Word, Excel, PowerPoint and Access. The course allows for a greater understanding of the software programs and allows students to learn advanced skills expected by college programs and employers.

### **T1141 Principles of Marketing**

**Open to grades 10, 11, 12**

**1 semester, 1 credit per sem.**

**Approximate cost per semester: \$31.00**

**Meets requirements: THD, AHD, Core 40 (Directed Elective or Elective), GS**

**Dual Credit: Ivy Tech Community College**

**Aligned With: Indiana Core Transfer Library course Principles of Marketing**

Students will learn business marketing, management, and business; communication and interpersonal skills; economics; and professional development foundations. Emphasis will be placed on both oral and written communication, business math, problem solving, Internet marketing, and thinking skills as they relate to financing, marketing, information management, pricing, product use, promotion, and selling.

### **T1131 Sports & Entertainment Marketing**

**Open to grades 10, 11, 12**

**1 semester, 1 credit per semester**

**Approximate cost per semester: \$7.22**

**Meets requirements: THD, AHD, Core 40 (Directed Elective or Elective)**

This class is a specialized marketing course that develops student understanding of the sport/event industries, their economic impact, and products; distribution systems and strategies; pricing considerations; product management; and promotion. Students are presented with problem solving situations requiring critical thinking skills.

### **T1151 Global Economics**

**Open to grade 12**

**1 semester, 1 credit per semester**

**Approximate cost per semester: \$54.70**

**Meets requirements: THD, AHD, Core 40 (Directed Elective or Elective), GS**

**Meets Economics credit for graduation**

Global Economics is a business course that provides students with an understanding of their role as consumers and producers in domestic and global economies. The course enables students to understand how the economic system operates while comprehending their role in that system. Students deal with public policy, international economics, microeconomics, and macroeconomics. Case studies, guest speakers, and simulations are strategies used in the instruction.

### **T1101 Personal Financial Responsibility**

**Open to grades 10, 11, 12**

**1 semester, 1 credit per sem.**

**Approximate cost per semester: \$0**

**Meets requirements: THD, AHD, Core 40 (Directed Elective or Elective)**

This class addresses the identification and management of personal financial resources to meet the financial needs and wants of individuals and families. Students in personal finance learn about business math, buying a car, buying a house, credit, insurance, budgeting, investing and taxes. Students learn to make better financial decisions that affect them now and in the future.

### **T1061 Introduction to Accounting**

**Open to grades 10, 11, 12**

**1 semesters, 1 credit per sem.**

**Approximate cost per semester: \$46.95 (13.20/sem + 33.75/year)**

**Meets requirements: THD, AHD, Core 40 (Directed Elective or Elective)**

Students learn the language of business using Generally Accepted Accounting Principles (GAAP) and procedures for proprietorships, partnerships and corporations using correct accounting steps. The entire cycle is covered from opening entries to closing entries. Balance Sheets, Income Statements, Cash Flow Statements and Owner Equity Statements are prepared. This is an excellent course for anyone considering a career in business.

### **T1062 Advanced Accounting**

**Open to grades 11, 12**

**2 semesters, 1 credit per sem.**

**Approximate cost per semester: \$46.09 (12.34/sem + 33.75/year)**

**Meets requirements: THD, AHD, Core 40 (Directed Elective or Elective)**

**Dual Credit: Ivy Tech Community College**

**Aligned With: Indiana Core Transfer Library course Financial Accounting**

**Prerequisite: Students must attain an average of C or better in Introduction to Accounting**

The second-year accounting class will be an expanded coverage of important topics such as financial planning, business and personal financial services, investments and securities, risk management, and corporate finance. The student will reach a new level of knowledge in accounting for the corporate world.

### **T1081 Business Law and Ethics**

**Open to grades 10, 11, 12**

**1 semester, 1 credit per sem**

**Approximate cost per semester: \$29.17**

**Meets requirements: THD, AHD, Core 40 (Directed Elective or Elective)**

**Dual Credit: Ivy Tech Community College**

**Aligned With: Indiana Core Transfer Library course Business Law**

The class provides an overview of the legal system in the business setting. Topics include contracts, personal, employment, and property law. Students learn about ethics, criminal law (including the death penalty), torts, criminal and civil trial procedure, contracts, and wills. Students gain an understanding of these topics through class discussions, creating presentations, research, case studies, mock trials, guest speakers and a field trip to the local jail and courthouse.



**T1091 Princ. of Business Management  
(Entrepreneurship)**

Open to grades 11, 12

1 semester, 1 credit per sem

Approximate cost per semester: \$55.89

Meets requirements of: THD, AHD, Core 40 (Directed Elective or Elective)

Dual Credit: Ivy Tech Community College

Aligned With: Indiana Core Transfer Library course Introduction To Business

This class focuses on the roles and responsibilities of managers as well as opportunities of becoming an entrepreneur. Students use skills in team building, leadership, problem solving steps and processes. The Business Management course seeks to develop sound management skills within students, as management plays a role in any future employment opportunity. Effective management requires decision-making abilities, long-range planning, knowledge, human relations expertise, motivational skills, and learning to build a business plan.

# C<sup>4</sup> AREA CAREER CONNECTION

## AGRICULTURAL SCIENCE & BUSINESS CLUSTER

**T50011 Intro to Agriculture Food & Natural Resources (5056)**

Open to grades 9, 10, 11, 12

2 semesters, 1 credit per semester

Approximate cost per semester: \$25.09

Meets requirements: THD, AHD, Core 40

This course prepares students who are interested in the study of Agriculture. Students complete projects and learning activities that focus on hands on real life situations in the study of: animals, plants, soil, food, horticultural sciences. There are also activities studying agricultural business management, landscape management, natural resources and careers in agriculture, leadership and supervised agricultural experience. An activity and project-based approach is used along with team-building to enhance the effectiveness of the student learning activities.

**T50031 Horticultural Science (5132)**

Open to grades 9, 10, 11, 12

2 semesters, 1 credit per semester

Approximate cost per semester: \$19.44

Meets requirements: THD, AHD, Core 40

Dual Credit Available

Students explore the life cycle of plants. They learn how to care for plants, what requirements plants have for survival, the basics of landscape management, and the science behind nutrients found in plants and soil. Students have the opportunity to design an interior space using plants, design bouquets and other arrangements, as well as adopt a plant of their own to care for.

**T50041 Natural Resources (5180)**

Open to grades 9, 10, 11, 12

2 semesters, 1 credit per semester

Approximate cost per semester: \$10.00

Recommendation(s): Introduction to Agriculture Food and Natural Resources, Horticultural Science

Dual Credit Available

Natural Resources provides students with a foundation in natural resources. Hands-on learning activities in addition to leadership development, supervised agricultural experience and career exploration encourage students to investigate areas of environmental concern. Students are introduced to the following areas of natural resources: soils, the water cycle, air quality, outdoor recreation, forestry, rangelands, wetlands, animal wildlife and safety.

**T50061 Animal Science (5008)**

Open to grades 10, 11, 12

2 semesters, 1 credit per semester

Approximate cost per semester: \$23.28

Meets requirements: THD, AHD, Core 40

Recommendation(s): Intro to Agriculture Food & Natural Resources

Dual Credit Available

This course is a year-long program that provides students with an overview of the field of animal science. Students participate in a large variety of activities and laboratory work including real and simulated animal science experiments and projects. All areas that the students study can be applied to both large and small animals. Topics addressed include: anatomy and physiology, genetics, reproduction, nutrition, aqua-culture, careers related to the industry, and management practices for the care and maintenance of animals.

**T25501 Advanced Life Science: Animals (5070)**

Open to grades 11, 12

2 semesters, 1 credit per semester

Approximate cost per semester: \$25.77

Meets requirements: THD, AHD, Core 40, NCAA Recommendation(s):

Two years of Core 40/AHD Science Note: This course counts toward Core 40 Science credits.

This course is a standards-based, interdisciplinary science course that integrates biology, chemistry, and microbiology in an agricultural context. Students formulate, design, and carry out animal-based laboratory and field investigations as an essential course component. They investigate key concepts that enable them to understand animal growth, development, and physiology as it pertains to agricultural science. This course stresses the unifying themes of both biology and chemistry as students work with concepts associated with animal taxonomy, life at the cellular level, organ systems, genetics, evolution, ecology, and historical and current issues in animal agriculture. Students apply the principles of scientific inquiry to solve problems related to biology and chemistry in highly advanced agricultural applications of animal development.

**T25502 Advanced Life Science: Foods (5072)**

Open to grades 11, 12

2 semesters, 1 credit per semester (may include travel period)

Approximate cost per semester: \$68.38

Meets requirements: THD, AHD, Core 40, NCAA Recommendation: Two years of Core 40/AHD Science Note: This course counts toward Core 40 Science credits.

Note: Qualifies as a Quantitative Reasoning course for the General, Core 40, AHD and THD diplomas.

This two-semester course provides students with opportunities to participate in a variety of activities including laboratory work. This is a standards-based, interdisciplinary science course that integrates biology, chemistry and microbiology in the context of foods and the global food industry. Students formulate, design and carry out food-based laboratory and field investigations. Students understand

how biology, chemistry and physics principles apply to the composition of foods, the nutrition of foods, food and food product development, food processing, food safety and sanitation, food packaging and food storage. Students will be able to apply the principles of scientific inquiry to solve problems related to biology, physics and chemistry in the context of highly advanced industry applications of foods.

## **BUSINESS CLUSTER**

### **T51111 Digital Applications and Responsibility I (4528)**

**Open to grades 9, 10, 11, 12**

**1 semester, 1 credit per semester**

**Approximate cost per semester: \$58.80**

**Meets requirements: THD, AHD, Core 40**

This course provides the student an opportunity to become proficient in the Microsoft software programs that include: Word, Excel and Powerpoint. Students learn to use these programs efficiently and thoroughly. This is an excellent course for those needing basic computer skills expected by employers and used in college.

### **T51112 Digital Applications and Responsibility II (4528)**

**Open to grades 9, 10, 11, 12**

**1 semester, 1 credit per semester**

**Approximate cost per semester: \$58.80**

**Meets requirements: THD, AHD, Core 40**

This is a comprehensive course designed for advanced users allowing them to become proficient in Microsoft Word, Excel and PowerPoint and Access. This course allows for a greater understanding of the software programs and allows students to learn advanced skills expected by college programs and employers.

### **T51011 Personal Financial Responsibility (4540)**

**Open to grades 10, 11, 12**

**1 semester, 1 credit**

**Approximate cost per semester: \$13.56**

**Meets requirements: THD, AHD, Core 40**

This course is designed to help a person properly manage money in today's environment. This course benefits the college preparatory and non-college preparatory student. Areas of study include personal financial planning, financial statements, services, budgeting, investments, portfolio management, interpreting financial statement, stocks vs. bonds, insurance protections, credit management, consumer purchases, rights and responsibilities, a decision-making skill for all aspects of life as consumers, producers, entrepreneurs and economic citizens. Instructional strategies may include use of projects, cooperative learning, simulations, real world experiences, guest speakers, Internet research and computer/technology applications.

### **T51081 Business Law and Ethics (4560)**

**Open to grades 10, 11, 12**

**2 semesters, 1 credit per semester**

**Approximate cost per semester: \$40.86**

**Meets requirements: THD, AHD, Core 40 Dual Credit Available**

Students learn about ethics, criminal law, torts, criminal and civil trial procedure, contracts and wills. Students gain an understanding of these topics through class discussions, creating presentations, research, case studies, mock trials and guest speakers.

### **T51061 Introduction to Accounting (4524)**

**Open to grades 10, 11, 12**

**2 semesters, 1 credit per semester**

**Approximate cost per semester: \$66.20**

**Meets requirements: THD, AHD, Core 40**

**Note: Qualifies as a Quantitative Reasoning course for General Diploma only.**

Students learn the introduction to principles and procedures for proprietorships, partnerships and corporations using correct accounting steps. The entire cycle is covered from opening entries to closing entries. Balance Sheets, Income Statements, Distribution Statements and Owner Equity Statements are prepared. This is an excellent course for anyone considering a career in business.

### **T51062 Advanced Accounting (4522)**

**Open to grades 11, 12**

**2 semesters, 1 credit per semester (2 semesters required)**

**Required Prerequisites: Introduction to Accounting**

**Approximate cost per semester: \$66.20**

**Meets requirements of: THD, AHD, Core 40**

**Qualifies as a Quantitative Reasoning course**

*Advanced Accounting* expands on the Generally Accepted Accounting Principles (GAAP) and procedures for proprietorships and partnerships using double-entry accounting covered in Introduction to Accounting. Emphasis is placed on accounting principles as they relate to both manual and automated financial systems. This course involves understanding, analyzing, and recording business transactions and preparing, analyzing, and interpreting financial reports as a basis for decision-making. Students are required to take Introduction to Accounting prior to enrollment in this course.

### **T51062 Banking and Investment Capstone (5258)**

**Open to grades 11, 12**

**2 semesters, 1 credit per semester (2 semesters required)**

**Approximate cost per semester: \$46.09**

**Meets requirements: THD, AHD, Core 40**

**Prerequisite: Student must attain an average of C or better in Introduction to Accounting**

**Dual Credit Available**

**Note: Qualifies as a Quantitative Reasoning course**

Banking and Investment Capstone addresses the need of schools in areas that have workforce demand in the finance industry. It analyzes and synthesizes high-level skills needed for a multitude of careers in the banking and investment industry. Students learn banking, investments and other finance fundamentals and applications related to financial institutions, business and personal financial services, investment and securities, risk management products and corporate finance. The course provides students with work based learning experiences to acquire and apply knowledge and skills in one or more careers in the industry.

### **T51141 Principles of Marketing (5914)**

**Open to grades 11, 12**

**2 semesters, 1 credit per semester**

**Approximate cost per semester: \$43.42**

**Meets requirements: THD, AHD, Core 40**

**Dual Credit Available**

This course provides a basic introduction to the scope and importance of marketing in the global economy. Emphasis is placed on oral and written communications, mathematical applications, problem solving, and critical thinking skills as they relate to advertising/promotion/selling, distribution, financing, marketing-information management, pricing and product/service management.

### **T51091 Principles of Business Management (4562)**

**Open to grades 11, 12**

**2 semesters, 1 credit per semester**

**Approximate cost per semester: \$23.02**

**Meets requirements: THD, AHD, Core 40**

**Dual Credit Available**

This course describes the rewards, benefits and privileges managers might expect in their day to day activities. It also investigates the challenges faced by many managers today. Students learn the characteristics of a good leader. Staying ahead of their rivals, managers must be able to manage diversity in the workplace, globalization, information technology advancements, maintain high ethical standards, be aware of personal happiness of employees and life goals. Students learn how managers must plan, organize, lead and control all aspects of a business while maintaining effectiveness and efficiency within the organization.

**T551131 Sports & Entertainment Marketing (5984)****Open to grades 11, 12****2 semesters, 1 credits per semester****Approximate cost per semester: \$17.38****Meets requirements: THD, AHD, Core 40****Prerequisite(s): Principles of Marketing or Principles of Business Management**

This course is a specialized marketing course that develops student understanding of the sport/event industries, their economic impact, and products; distribution systems and strategies; pricing considerations; product/service management, and promotion. Students acquire an understanding and appreciation for planning. Throughout the course, students are presented problem-solving situations for which they must apply academic and critical-thinking skills. Participation in cooperative education is an optional instructional method, giving students the opportunity to apply newly acquired marketing skills in the workplace.

**T51231 Marketing in Hospitality and Tourism (5982)****Open to grades 11, 12****2 semesters, 1 credits per semester****Approximate cost per semester: TBD****Meets requirements: THD, AHD, Core 40****Prerequisite: Principles of Marketing or Principles of Business Management**

This course is a specialized marketing course that develops student understanding of marketing in the hospitality, travel, and tourism industry. Students gain knowledge and skills in marketing-information management, pricing, product/service management, promotion, and selling in the hospitality, travel, and tourism industry.

**COMMUNICATIONS CLUSTER****T52111 Design Fundamentals (4834)****Open to grades 9, 10, 11, 12****2 semesters, 1 credits per semester****Approximate cost per semester: \$3.50****Meets requirements: THD, AHD, Core 40****Dual Credit is Available**

This course introduces students to fundamental design theory. Investigations into design theory and color dynamics will provide experiences in applying design theory, ideas and creative problem solving in the areas of communication technology. Student experiences encompass aspects of art in communication, integration of art in communication and incorporate literacy and presentation skills.

**T52022 Graphic Design and Layout (5550)****Open to grades 10, 11, 12****2 semesters, 2 credits per semester****Approximate cost per semester: \$27.00****Meets requirements: THD, AHD, Core 40****Recommendation(s): Design Fundamentals,(MM) Introduction to Communication****Dual Credit Available**

In this course more emphasis is placed on color and full-color process printing. Larger-sized projects to fit the larger offset presses will also be included. This course also includes organized learning experiences that incorporate a variety of visual art techniques as they relate to the design and execution of layouts and illustrations for advertising, displays, promotional materials, and instructional manuals. Instruction also covers advertising theory and preparation of copy, lettering, posters, and artwork in addition to incorporation of photographic images. Communication skills will be emphasized through the study of effective methods used to design commercial products that impart information and ideas. Advanced instruction might also include experiences in various printing processes as well as activities in designing product packaging and commercial displays or exhibits.

**T52032 Graphic Imaging Technology (5572)****Open to grades 11, 12****2 semesters, 2 credits per semester****Approximate cost per semester: \$13.50****Meets requirements: THD, AHD, Core 40****Prerequisite(s): T52022 Graphic Design and Layout****Dual Credit Available**

This course includes organized learning experiences that focus on theory and laboratory activities in prepress, press and finishing operations. Emphasis is placed on elements of design and layout leading to computerized electronic image generation, plate preparation, pressroom operations and finishing techniques. Instructional activities enhance student's language arts skills through the use of proofreading, spelling and punctuation exercises. The course includes actual production processes in conjunction with classroom assignments embracing the technologies of printing, publishing, packaging, electronic imaging and their allied industries.

**T52212 3-D Computer Animation & Visualization (5530)****Open to grades 10, 11, 12****2 semesters, 2 credits per semester****Approximate cost per semester: \$27.00****Meets requirements: THD, AHD, Core 40****Recommendation(s): MM Introduction to Communications or Design Fundamentals****Dual Credit Available**

This course introduces and explores three-dimensional animation techniques as used by the animation and graphics industry today. It applies the use of 3-D computer animation, digital video output and a variety of computer technologies to produce digital images. Course assignments stress the use of current strategies to solve two-dimensional layout and three-dimensional modeling problems. Students are responsible for the design, development and production of a graphics and video-based digital animation product.

**T52222 Interactive Media (5232)****Open to grades 11, 12****2 semesters, 2 credits per semester****Approximate cost per semester: \$27.00****Meets requirements: THD, AHD, Core 40****Prerequisite(s): 3D Computer Illustration and Graphics****Dual Credit Available**

This is the second-year offering to follow 3-D Computer Illustration and Graphics. This is a continuation of the first-year program. Animation, modeling, graphics, engineering design, electronic publishing and illustration will be studied in greater detail. Students plan and implement projects approved by the instructor. The projects should demonstrate an advanced level of design competency in computer graphics and be performed in consultation with the teacher and industry advisors.

**T52412 Radio and Television I (5986)****Open to grades 10, 11, 12****2 semesters, 2 credits per semester****Approximate cost per semester: \$38.06****Meets requirements: THD, AHD, Core 40****Recommendation(s): Design Fundamentals, (MM) Introduction to Communication****Dual Credit Available**

*Radio and Television I* provides instruction to develop and enhance competencies in various communication, marketing, media, production and technical functions and tasks performed by employees, including management personnel in TV broadcasting and telecommunications occupations. Emphasis is placed on production, motion graphics (Adobe Creative Suite), programming, broadcast writing, broadcast reporting and broadcast equipment operation. Instructional strategies include hands-on activities where students create commercials, TV broadcasts, sportscasts, new programs and other production related projects.

**T52422 Radio and Television II (5992)**

Open to grades 11, 12

2 semesters, 2 credits per semester

Approximate cost per semester: \$38.06

Meets requirements: THD, AHD, Core 40

Recommendation(s): Radio and Television 1

Dual Credit Available

Radio and Television 2 continues the instruction to develop and enhance competencies in TV broadcasting and telecommunications occupations. Emphasis is placed on production, motion graphics (Adobe Creative Suite), programming, broadcast writing, broadcast reporting and broadcast operation. Instructional strategies include hands-on activities where students create commercials, TV broadcasts, sportscasts, new programs and other production related projects.

**T52612 Radio and Television I: BNN (5986)****T52622 Radio and Television II: BNN (5992)**

Open to grades 10, 11, 12

2 semesters, 2 credits per semester

Approximate cost per semester: \$38.06

Meets requirements: THD, AHD, Core 40

Prerequisite(s): (Introduction to Communications, Journalism 1), Application, interview and portfolio required for crew positions.

Note: Student crew members are often required to spend several hours before and after-school.

Dual Credit Available

Radio and Television I & II provides instruction to develop and enhance competencies in various communication, marketing, media, production and technical functions and tasks performed by employees, including management personnel in TV broadcasting and telecommunications occupations. Student will participate in the CNHS videos and filmed magazine programs.

**T52512 Radio & Television I: Olympian Flame (5986)****T52522 Radio & Television II: Olympian Flame (5992)**

Open to grades 10-12

2 semesters, 2 credits per semester

Approximate cost per semester: Fees to be determined

Meets requirements of: THD, AHD, Core 40

Prerequisite: Instructor Approval

Recommendation(s): T46402 Radio and Television I

Dual Credit Available

Radio and Television I & II: Olympian Flame is a course where individuals and student groups will create and present a student/school community morning news program. Students will help to write, graphically design, shoot, organize and use all the telecommunications computer technologies involved with the creation of a morning newscast. Students will explore related career options through field trips to commercial broadcasting outlets.

## COMPUTER TECHNOLOGY CLUSTER

**T53111 Computer Tech Support (5230)**

Open to grades 9, 10, 11, 12

2 semesters, 1 credit per semester

Approximate cost per semester: \$56.00

Meets requirements: THD, AHD, Core 40

Recommendation: Digital Applications and Responsibility or Electronics Computer Technology I I

Computer Tech Support allows students to explore how computers work. Students learn the functionality of hardware and software components as well as suggested best practices in maintenance and safety issues. Through hands on activities and labs, students learn how to assemble and configure a computer, install operating systems and software and troubleshoot hardware and software problems. Students may earn an industry-based certification at the end of the course.

**T53112 Networking 1 (5234)**

Open to grades 10, 11, 12

2 semesters, 2 credits per semester

Approximate cost per semester: \$27.00

Meets requirements: THD, AHD, Core 40

Recommendation: Computer Tech Support

Networking Fundamentals introduces students to concepts of local and wide area networks, home networking, networking standards using the IEEE/OCI Model, network protocols, transmission media and network architecture/topologies. Security and data integrity are introduced and emphasized throughout this course. The purpose of this course is to offer students the critical information needed to successfully move into a role as an IT professional supporting networked computers. Concepts covered include TCP/IP client administration, planning a network topology, configuring the TCP/IP protocol, managing network clients, configuring routers and hubs as well as creating a wireless LAN.

**T53132 Networking 2: Infrastructure (5257)**

Open to grades 11, 12

2 semesters, 2 credits per semester

Approximate cost per semester: TBD

Meets requirements: THD, AHD, Core 40

Prerequisites: T53112 Networking 1

This course focuses on the software skills needed to manage a network. Students learn and practice skills necessary to perform in the role of a network administrator. They will be able to accomplish fundamental network management tasks on a server such as setup of computer network services, create users and appropriate login scripts, develop groups, set the server remotely, set up security, backup/restore the server and setup/maintain clients.

**T53122 Networking 2: Servers (4588)**

Open to grades 11, 12

2 semesters, 2 credits per semester

Approximate cost per semester: TBD

Meets requirements of: THD, AHD, Core 40

Prerequisites: Networking 1

Networking 2: Servers focuses on learning the fundamentals of networking, routing, switching and related protocols. In this course, students learn both the practical and conceptual skills that build the foundation for understanding basic networking, routing and switching. Students are introduced to the two major models used to plan and implement networks: OSI and TCP/IP. The OSI and TCP/IP functions and services are examined in detail. Students will learn how a router addresses remote networks and determines the best path to those networks, employing static and dynamic routing techniques.

## CONSTRUCTION ENGINEERING TECHNOLOGY CLUSTER

**T54011 Civil Engineering & Architecture (5650)**

Open to grades 9, 10, 11, 12

2 semesters, 1 credit per semester

Approximate cost per semester: \$20.00

Meets requirements: THD, AHD, Core 40

Note: Qualifies as a Quantitative Reasoning course for the General, Core 40, AHD and THD diplomas

Civil Engineering and Architecture (Drafting) introduces students to the fundamental design and development aspects of civil engineering and architectural planning activities. Application and design principles are used in conjunction with mathematical and scientific knowledge. Computer software programs should allow students opportunities to design, simulate, and evaluate the construction of buildings and communities. During the planning and design phases, instructional emphasis should be placed on related transportation, water resource, and environmental issues. Activities include the preparation of cost estimates as well as a review of regulatory procedures that would affect project design.

**T54012 Architectural Drafting and Design 1 (5640)****Open to grades 10, 11, 12****2 semesters, 1 credits per semester****Approximate cost per semester: \$20.00****Meets requirements: THD, AHD, Core 40****Recommendation(s): Civil Engineering & Architecture, Computers in Design and Production****Dual Credit Available**

This course provides students with a basic understanding of the detailing skills commonly used by a drafting technician. Areas of study include: lettering, sketching, proper use of equipment, geometric constructions with emphasis on orthographic (multiview) drawings that are dimensioned and noted to ANSI standards. This course includes the creation and interpretation of construction documents. Methods of geometric construction, three dimensional drawing techniques, and sketching will be presented as well as elementary aspects of residential design and site work. Areas of emphasis include print reading and drawing. Another purpose of this course is to provide students with a basic understanding of the features and considerations associated with the operation of a computer-aided design (CAD) system. Students gain valuable hands-on experience with AutoCAD.

**T54022 Architectural Drafting and Design 2 (5652)****Open to grades 11, 12****2 semesters, 2 credits per semester****Approximate cost per semester: \$20.00****Meets requirements: THD, AHD, Core 40****Prerequisite(s): Architectural Drafting & Design 1****Dual Credit Available****Note: Qualifies as a Quantitative Reasoning course for the General, Core 40, AHD and THD diplomas.**

This course presents a history and survey of architecture and focuses on creative design of buildings in a studio environment. Covers problems of site analysis, facilities programming, space planning, conceptual design, proper use of materials, selection of structure and construction techniques. Develops presentation drawings, and requires oral presentations and critiques. Generation of form and space is addressed through basic architectural theory, related architectural styles, design strategies, and a visual representation of the student's design process. Advanced CAD enables students to make the transition from 2D drafting to 3D modeling. Various architectural software packages and application may be used.

**T54111 Introduction to Construction (4792)****Open to grades 9, 10, 11, 12****2 semesters, 1 credits per semester****Approximate cost per semester: \$10.00****Meets requirements: THD, AHD, Core 40**

This course offers hands-on activities and real world experiences related to the skills essential in residential, commercial and civil building construction. During the course students are introduced to the history and traditions of construction trades. Students also learn and apply knowledge of the care and safe use of hand and power tools as related to each trade. In addition, students are introduced to blueprint reading, applied math, basic tools and equipment, and safety. Students will demonstrate building construction techniques, including concrete and masonry, framing, electrical, plumbing, dry walling, HVAC, and painting as developed locally in accordance with available space and technologies. They also investigate topics related to the purchasing and maintenance of structures, special purpose facilities, green construction and construction careers.

**T54112 Construction Trades 1 (5580)****Open to grades 10, 11, 12****2 semesters, 2 credits per semester****Approximate cost per semester: \$56.70****Meets requirements: THD, AHD, Core 40****Recommendation(s): Introduction to Construction****Dual Credit Available**

This course includes classroom and laboratory experiences covering the formation, installation, maintenance, and repair of buildings, homes, and other structures. This course also covers the use of working drawings and applications from the print to the work. Students explore the relationship of views and details, interpretation

of dimension, transposing scale, tolerance, electrical symbols, sections, materials list, architectural plans, geometric construction, three dimensional drawing techniques, and sketching. Elementary aspects of residential design and site work will also be covered. Areas of emphasis will include print reading and drawing, room schedules and plot plans. Students will develop an understanding and interpretation of the Indiana Residential Code for one and two-family dwellings and safety practices including Occupational Safety and Health Administration's Safety & Health Standards for the construction industry.

**T54122 Construction Trades 2 (2 hour) (5578)****T54123 Construction Trades 2 (3 hour) (5578)****Open to grades 11, 12****2 semesters, 2 credits per semester****Approximate cost per semester: \$56.70****Meets requirements: THD, AHD, Core 40****Prerequisite(s): Construction Trades 1****Dual Credit Available**

This course builds on the topics covered in Construction Trades 1 and includes: formation, installation, maintenance, and repair of buildings, homes, and other structures including recent trends in the residential construction industry. Information is presented concerning materials, occupations, and professional organizations within the industry. Students will develop basic knowledge, skills, and awareness of interior trim. It provides training in installation of drywall, moldings, interior doors, kitchen cabinets, and baseboard moldings. Students also develop skills in the finishing of building exteriors. They also explore skills in the installation of cornices, windows, doors and various types of sidings used in today's marketplace. Additionally, the course covers design and construction of roof systems and using framing squares for traditional rafter and truss roofing.

**T54212 Construction Trades: Electrical 1 (2 hour) (4830)****T54213 Construction Trades: Electrical 1 (3 hour) (4830)****Open to grades 11, 12****2 semesters, 2 credits per semester****Approximate cost per semester: \$51.70****Meets requirements: THD, AHD, Core 40****Prerequisite(s): Construction Trades 2****Dual Credit Available**

This course includes classroom and laboratory experiences emphasizing the operation, maintenance and safe use of various tools including the builder's level and transit. It also covers the history of building construction to present-day applications emphasizing future trends and construction as a career. It provides instruction and practice in the use of working drawings and applications from blueprint to worksite. Students examine relationship of views and details, interpretation of dimension, transposing scale, tolerance, electrical symbols, sections, materials list, architectural plans, room schedules and plot plans. It covers both AC and DC circuits. Students will use mathematical principles to solve electrical problems and to troubleshoot electrical circuits.

**T54222 Construction Trades: Electrical 2 (2 hour) (4832)****T54223 Construction Trades: Electrical 2 (3 hour) (4832)****Open to grades 12****2 semesters, 2 credits per semester****Approximate cost per semester: \$51.70****Meets requirements: THD, AHD, Core 40****Prerequisite(s): Construction Trades: Electrical 1****Dual Credit Available****Note: Qualifies as a Quantitative Reasoning course for the General diploma only.**

This course includes classroom and laboratory experiences concerned with the practice of residential wiring, including electrical service, metering equipment, lighting, switches, outlets and other common components, and methods of installation and maintenance of the residential wiring system in accordance with the current National Electrical Code. Studies include mechanical installation of hardware as well as electrical design and layout. This course also focuses on tool use, material selection, and installation of machines in the industrial g.

# ENGINEERING MANUFACTURING TECHNOLOGY CLUSTER

## Project Lead The Way: A Pre-Engineering Program

PLTW's Pathway to Engineering (PTE) is designed to encompass all four years of high school. Courses are centered on activities that are hands-on and project-based. Students develop critical thinking and problem solving skills while using the same industry-leading 3D design software used by companies like Intel, Lockheed Martin and Pixar.

They explore aerodynamics, manufacturing and alternative energy; and apply biological and engineering concepts related to biomechanics – think robotics. Students design, test and actually construct circuits and devices such as smart phones and tablets. And work collaboratively on a culminating capstone project.

Project Lead The Way courses have dual credit options with several universities across the country. See a PLTW instructor or go to: [www.pltw.org](http://www.pltw.org) for complete information.

### **T55071 PLTW: Introduction to Engineering Design (4812)**

**Open to grades 9, 10, 11, 12**

**2 semesters, 1 credit per semester**

**Approximate cost per semester: \$23.44**

**Meets requirements: THD, AHD, Core 40**

**Recommendation(s): Algebra**

**Dual Credit Available**

This is an introductory course which develops student problem solving skills using the design process. Students document their progress of solutions as they move through the design process. Students develop solutions using elements of design and manufacturability concepts. They develop hand sketches using 2D and 3D drawing techniques. Computer Aided Design (CAD).

### **T55081 PLTW: Principles of Engineering (4814)**

**Open to grades 10, 11, 12**

**2 semesters, 1 credit per semester**

**Approximate cost per semester: \$23.44**

**Meets requirements: THD, AHD, Core 40**

**Recommendation(s): Introduction to Engineering Design or Instructor Approval**

**Dual Credit Available**

**Note: Qualifies as a Quantitative Reasoning course for the General, Core 40, AHD and THD diplomas.**

This course focuses on the process of applying engineering, technological, scientific and mathematical principles in the design, production, and operation of products, structures, and systems. It is designed to provide students interested in engineering careers to explore experiences related to specialized fields such as civil, mechanical, and materials engineering. Students will engage in research, development, planning, design, production, and project management to simulate a career in engineering. The topics of ethics and the impacts of engineering decisions are also addressed. Classroom activities are organized to allow students to work in teams and use modern technological processes, computers, CAD software, and production systems in developing and presenting solutions to engineering problems.

### **T55061 PLTW: Digital Electronics (4826)**

**Open to grades 11, 12**

**2 semesters, 1 credit per semester**

**Approximate cost per semester: \$23.44**

**Meets requirements: THD, AHD, Core 40**

**Recommendation(s): Introduction to Engineering Design, Principles of Engineering**

**Dual Credit Available**

**Note: Qualifies as a Quantitative Reasoning course for the General, Core 40, AHD and THD diplomas.**

This is a course of study in applied digital logic that encompasses the design and application of electronic circuits and devices found in video games, watches, calculators, digital cameras, and thousands of other devices. Instruction includes the application of engineering and

scientific principles as well as the use of Boolean algebra to solve design problems. Using computer software that reflects current industry standards, activities should provide opportunities for students to design, construct, test, and analyze simple and complex digital circuitry software will be used to develop and evaluate the product design. This course engages students in critical thinking and problem-solving skills, time management and teamwork skills.

### **T55051 PLTW: Computer Integrated Manufacturing (4810)**

**Open to grades 11, 12**

**2 semesters, 1 credit per semester**

**Approximate cost per semester: \$23.44**

**Meets requirements: THD, AHD, Core 40**

**Recommendation(s): Introduction to Engineering Design, Principles of Engineering**

**Dual Credit Available**

**Note: Qualifies as a Quantitative Reasoning course for the General, Core 40, AHD and THD diplomas.**

This course applies principles of rapid prototyping, robotics, and automation. This course builds upon the computer solid modeling skills developed in Introduction of Engineering Design. Students will use computer controlled rapid prototyping and CNC equipment to solve problems by constructing actual models of their three-dimensional designs. Students will also be introduced to the fundamentals of robotics and how this equipment is used in an automated manufacturing environment. Students will evaluate their design solutions using various techniques of analysis and make appropriate modifications before producing their prototypes.

### **T55091 PLTW: Engineering Design & Development (4828)**

**Open to grades 12**

**2 semesters, 1 credit per semester**

**Approximate cost per semester: \$23.44**

**Meets requirements: THD, AHD, Core 40**

**Recommendation(s): Introduction to Engineering Design, Principles of Engineering and one specialty course.**

**Note: Qualifies as a Quantitative Reasoning course for the General, Core 40, AHD and THD diplomas.**

**Note: With approval, qualified PLTW student may use this project for their Senior Project at CEHS and CNHS.**

This is an engineering research course in which students work in teams to research, design, test, and construct a solution to an open-ended engineering problem. The product development life cycle and a design process are used to guide the team to reach a solution to the problem. The team presents and defends their solution to a panel of outside reviewers at the conclusion of the course. The EDD course allows students to apply all the skills and knowledge learned in previous pre-engineering courses. The use of 3D design software helps students design solutions to the problem their team has chosen. This course also engages students in critical thinking and problem-solving skills, time management and teamwork skills, a valuable set for students' future careers.

### **T55501 Computers in Design and Production (4800)**

**Open to grades 9, 10, 11, 12**

**2 semesters, 1 credit per semester**

**Approximate cost per semester: \$10.00**

**Meets requirements of: THD, AHD, Core 40**

This course specializes in using modern technological processes, computers, design, and production systems in the production of products and structures through the use of automated production systems. Emphasis is placed on using modern technologies and on developing career related skills for electronics, manufacturing, precision machining, welding, and architecture career pathways. Students apply ingenuity using tools, materials, processes, and resources to create solutions as it applies in the electronics, manufacturing, precision machining, welding, and architecture. Course content should address major technological content related to topics such as: Architectural drawing and print design, design documentation using CAD systems; assignments involving the interface of CAD, CNC, CAM, and CIM technologies; computer simulation of products and systems; publishing of various media; animation and related multimedia applications; 3-D modeling of products or structures; digital creation and editing of graphics and audio files; control technologies; and automation in the modern workplace.

### **T55511 Introduction to Manufacturing (4784)**

**Open to grades 9, 10, 11, 12**

**2 semesters, 1 credit per semester**

**Approximate cost per semester: \$10.00**

**Meets requirements of: THD, AHD, Core 40**

This course specializes in how people use modern manufacturing systems with an introduction to manufacturing technology and its relationship to society, individuals, and the environment. An understanding of manufacturing provides a background toward developing engineering & technological literacy, developed through the study of the two major technologies, material processing and management technology, used by all manufacturing enterprises. Students will apply the skills and knowledge of using modern manufacturing processes to obtain resources and change them into industrial materials, industrial products and consumer products. Students will investigate the properties of engineered materials such as: metallics; polymers; ceramics; and composites. After gaining a working knowledge of these materials, students will study six major types of material processes: casting and molding; forming; separating; conditioning; finishing; and assembling.

### **T55612 Industrial Automation & Robotics I (5610)**

**Open to grades 10, 11, 12**

**2 semesters, 2 credit per semester**

**Approximate cost per semester: To Be Determined**

**Meets requirements: THD, AHD, Core 40**

**Recommendation(s): Introduction to Manufacturing, Computers in Design and Production, PLTW Introduction to Engineering Design**  
**Dual Credit available**

Industrial Automation & Robotics I will be a two-hour course that introduces students to curriculum covering the multi-craft skills needed by industrial technicians to complete the complex and varied tasks for the career. The year one curriculum will include OSHA 10 safety certification; basic electricity including electrical laws and principles of DC and AC currents; the basic theory, operation and programming of automated manufacturing systems; the basic principles and practices of mechanical technology; the common types of electrical wiring circuits used for power and control of electrical devices and motors used in manufacturing; and the common types of electrical wiring circuits used for power and control of electrical devices and motors used in advanced manufacturing. The year one curriculum will include General Industry: OSHA 10 safety certification.

### **T55622 Industrial Automation and Robotics II (5612)**

**Open to grades 11, 12**

**2 semesters, 2 credits per semester**

**Approximate cost per semester: TBD**

**Meets requirements of: THD, AHD, Core 40**

**Recommendation(s): Introduction to Manufacturing, Computers in Design and Production, PLTW Introduction to Engineering Design**  
**Prerequisite: Industrial Automation and Robotics I**

**Dual Credit available**

Industrial Automation and Robotics 2 includes the study of industrial robots, programming PLC's, automating cells, advanced programming and designing/building task oriented robots. Students will engage in active learning, critical thinking and problem solving through advanced robotic procedures and processes. Students will learn industrial robotic programming languages, strategies for automating to improve efficiencies and be introduced to advanced programming language that is common in global industry. Students will study basic computer numerical controlled (CNC) machining and will combine automation and CNC machining. They will apply information in real world situations to create working solutions and will complete projects, including building robots to perform tasks in autonomous mode and analyze their own career pathway in this sector.

### **T55212 Electronics and Computer Technology I (5684)**

**Open to grades 10, 11, 12**

**2 semesters, 2 credits per semester**

**Approximate cost per semester: TBD**

**Meets requirements of: THD, AHD, Core 40**

**Recommendation(s): (IT) Information Communications and Technology, Computers in Design and Production, PLTW Introduction to Engineering Design**

**Dual Credit Available**

This course introduces students to the fundamental electronic concepts necessary for entry into an electronic and computer systems career pathway, which will culminate with industry certifications or additional post-secondary education. Classroom and laboratory experiences will allow students begin their career preparation in the fundamental electronics concepts of Jobsite Skills, DC Basics, AC Basics, and Personal Computer Design, and will incorporate safety, technical writing, mathematical concepts, and customer service.

### **T55222 Electronics and Computer Technology II (5694)**

**Open to grades 11, 12**

**2 semesters, 2 credits per semester**

**Approximate cost per semester: \$48.12**

**Meets requirements: THD, AHD, Core 40**

**Prerequisite(s): Electronics & Computer Technology I**

**Dual Credit Available**

**Note: Qualifies as a Quantitative Reasoning course for the General, Core 40, AHD and THD diplomas.**

This course provides the opportunity for students to continue with foundational electronic concepts including circuit analysis and digital electronics modules. After completing the two additional foundational modules, student may choose to focus on one of the optional modules that can include more intense instruction, research, specialized projects, and internships. The optional modules include industrial technology, emerging electronic technologies, residential and commercial electronic communication, and automation. Classroom, laboratory, and work-based experiences in the fundamental electronics concepts of circuit analysis and digital electronics as well as one of the optional modules will incorporate safety, technical writing, mathematics, and customer service.

### **T55232 Electronics and Computer Technology III (5694)**

**Open to grades 12**

**2 semesters, 2 credits per semester**

**Approximate cost per semester: \$20.00**

**Meets requirements: THD, AHD, Core 40**

**Prerequisite(s): Electronics & Computer Technology II with a C or better**

Upon successful completion of the first two years of Electronics Technology students may be eligible to participate in a course where the student is involved in laboratory activities in advanced digital circuitry, microprocessors, personal computer troubleshooting and repair and programmable controller applications. Emphasis is on the design, circuit analysis and troubleshooting of these circuits. Opportunities for leadership skills, exposure to working in a team based work system and applications of technology will be given through participation with Skills USA. Qualified students may be eligible to participate in a School-To-Work placement.

### **T55112 Mechanical Drafting and Design I (4836)**

**Open to grades 10, 11, 12**

**2 semesters, 2 credits per semester**

**Approximate cost per semester: \$115.26**

**Meets requirements of: THD, AHD, Core 40**

**Recommendation(s): Computers in Design & Production, PLTW Introduction to Engineering Design**

**Dual Credit Available**

This course provides students with a basic understanding of the detailing skills commonly used by a drafting technician. Areas of study include lettering, sketching, proper use of equipment, geometric constructions with emphasis on orthographic (multiview) drawings that are dimensioned and noted to ANSI standards. Another purpose is to provide students with a basic understanding of the features and considerations associated with the operation of a computer-aided design (CAD) system. Students gain valuable hands-on experience with Auto CAD. They will complete several projects (increasing in difficulty) relating to command topics. Topics include: 2D drawing commands, coordinate systems, editing commands, paper and model space, inquiry commands, layers, plotting, text, and basic dimensioning.



### **T55122 Mechanical Drafting and Design II (4838)**

**Open to grades 11, 12**

**2 semesters, 2 credits per semester**

**Approximate cost per semester: \$115.26**

**Meets requirements: THD, AHD, Core 40**

**Prerequisite: Mechanical Drafting and Design I**

**Dual Credit Available**

**Note: Qualifies as a Quantitative Reasoning course for the General, Core 40, AHD and THD diplomas.**

This course covers working drawings both in detailing and assembly. This course presents fastening devices, thread symbols and nomenclature, surface texture symbols, classes of fits, and the use of parts lists, title blocks and revision blocks. This course will also focus on advanced CAD features, including fundamentals of three-dimensional modeling for design. This includes an overview of modeling, graphical manipulation, part structuring, coordinate system, and developing strategy of modeling. Advanced CAD will enable the student make the transition from 2D drafting to 3D modeling. Students will draw and calculate three dimensional problems. Theory and methods include graphic developments and the relationships between points, lines and planes, curved lines and surfaces, intersections, and development. Related computer software and hardware experiences will be covered.

### **T55132**

#### **Mechanical Drafting and Design III (4838)**

**Open to grades 12**

**2 semesters, 2 credits per semester**

**Approximate cost per semester: \$115.26**

**Meets requirements: THD, AHD, Core 40**

**Prerequisite: Mechanical Drafting and Design II with a C or better**

Upon successful completion of the first two years of Computer Aided Design students may be eligible to participate in a course where the student has the opportunity to effectively work with customized CAD software to meet specific discipline related requirements. Advanced modeling and rendering techniques are presented. School-to-work opportunities are available to senior students who qualify.

### **T55312 Precision Machining I (5782)**

**Open to grades 10, 11, 12**

**2 semesters, 2 credits per semester**

**Approximate cost per semester: \$57.24**

**Meets requirements: THD, AHD, Core 40**

**Recommendation(s): Computers in Design and Production, Introduction to Manufacturing**

**Dual Credit Available**

**Note: Qualifies as a Quantitative Reasoning course for the General diploma only.**

This course is designed to provide students with a basic understanding of the precision machining processes used in industry, manufacturing, maintenance, and repair. The course instructs the student in industrial safety, terminology, tools and machine tools, measurement and layout. Students will become familiar with the setup and operation of power saws, drill presses, lathes, milling machines, grinders and an introduction to CNC (computer controlled) machines.

### **T55322 Precision Machining II (5784)**

**Open to grades 11, 12**

**2 semesters, 2 credits per semester**

**Approximate cost per semester: \$57.24**

**Meets requirements: THD, AHD, Core 40**

**Prerequisites: Precision Machining I**

**Note: Qualifies as a Quantitative Reasoning course for the General, Core 40, AHD and THD diplomas.**

This course is a more in-depth study of skills learned in Precision Machining I with a stronger focus in CNC setup/operation/programming. Classroom activities concentrate on precision set-up and inspection work as well as machine shop calculations. Students develop skills in advanced machining and measuring parts involving tighter tolerances and more complex geometry. A continued focus on safety is also included.

### **T55332 Precision Machining III (5784)**

**Open to grade 12**

**2 semesters, 2 credits per semester**

**Approximate cost per semester: \$57.24**

**Meets requirements: THD, AHD, Core 40**

**Prerequisites: Precision Machining II with a C or better**

Upon successful completion of the first two years of Precision Machining, students may be eligible to participate in a course where the student studies advanced lathe work, milling operations, surface grinding, and computerized numerical control milling. Precision measurement, advanced blueprint reading, and industrial math are also taught. CNC programming and operating are taught first, second, and third year. Job opportunities in machine trades are tremendous. Qualified students are eligible for a school-to-work placement in the community.

### **T55412 Welding Technology I (5776)**

**Open to grades 10, 11, 12**

**2 semesters, 2 credits per semester**

**Approximate cost per semester: \$51.24**

**Meets requirements: THD, AHD, Core 40**

**Recommendation(s): Computers in Design and Production, Introduction to Manufacturing**

**Dual Credit Available**

This course includes classroom and laboratory experiences that develop a variety of skills in Oxy-fuel Cutting and Shielded Metal Arc Welding (SMAW). This course is designed for individuals who intend to make a career as a Welder, Technician, Sales, Designer, Researcher or Engineer. Emphasis is placed on safety at all times. OSHA standards and guidelines endorsed by the American Welding Society (AWS) are used. Instructional activities emphasize properties of metals, safety issues, blueprint reading, electrical principles, welding symbols, and mechanical drawing

### **T55422 Welding Technology II (5778)**

**Open to grades 11, 12**

**2 semesters, 2 credits per semester**

**Approximate cost per semester: \$51.24**

**Meets requirements: THD, AHD, Core 40**

**Prerequisite(s): Welding Technology I**

**Dual Credit Available**

**Note: Qualifies as a Quantitative Reasoning course for the General, Core 40, AHD and THD diplomas.**

Welding Technology 2 builds on the Gas Metal Arc Welding, Flux Cored Arc Welding, Gas Tungsten Arc Welding, Plasma Cutting and Carbon Arc skills covered in Welding Technology I. Emphasis is placed on safety at all times. OSHA standards and guidelines endorsed by the American Welding Society (AWS) are used. Instructional activities emphasize properties of metals, safety issues, blueprint reading, electrical principles, welding symbols, and mechanical drawing through projects and exercises that teach students how to weld and be prepared for college and career success.

### **T55432 Welding Technology III (5778)**

**Open to grade 12**

**2 semesters, 2 credits per semester**

**Approximate cost per semester: \$51.24**

**Meets requirements: THD, AHD, Core 40**

**Prerequisite(s): Welding Technology II with a C or better**

Upon successful completion of the first two years of Welding, students may be eligible to participate in a course where the student will be prepared for Advanced Placement and/or advanced welding techniques. Lab activities are patterned after a project-oriented job-shop and students will be graded on the quality of projects that they get done and/or their Advanced Placement Evaluations. As advanced students they will be overseeing younger students and learning management skills and team building efforts. At the end of a student's senior year or third year of welding, an AWS welding certification is offered at the student's expense. This certificate can be used to fulfill requirements for a Technical Honors Diploma.

# HEALTH SCIENCES CLUSTER

## Project Lead the Way (PLTW): Biomedical Sciences

The Project Lead the Way Biomedical Sciences program is a dynamic high school program which uses real-world problems to engage and challenge students. Students interested in math, science and the human body will find the PLTW Biomedical Sciences program a great introduction to numerous medical fields. It also teaches how the skills they learn are used in the biomedical sciences.

### T56101 PLTW Principles of the Biomedical Sciences (5218)

**Open to grades 9, 10, 11, 12**

**2 semesters, 1 credit per semester**

**Approximate cost per semester: \$52.44**

**Meets requirements: THD, AHD, Core 40**

**Prerequisites: Enrolled in Biology, college prep math and science**

**Dual Credit Available**

**Note: This course counts towards Core 40 science credits.**

Students explore the concepts of human medicine and are introduced to research processes, using applied math and science to solve problems. Hands-on, interactive projects enable students to investigate human body systems and various health conditions, including heart disease, diabetes, sickle-cell disease, hypercholesterolemia and infectious diseases. Key biological concepts include homeostasis, metabolism, inheritance of traits, feedback systems and defense against disease. Engineering principles such as the design process, feedback loops, fluid dynamics and the relationship of structure to function will be included where appropriate.

### T56201 PLTW Human Body Systems (5216)

**Open to grades 10, 11, 12**

**2 semesters, 1 credit per semester**

**Approximate cost per semester: \$52.44**

**Meets requirements: THD, AHD, Core 40**

**Recommendation(s): PLTW Principles of the Biomedical Sciences**

**Prerequisites: College prep math and science**

**Note: This course counts towards Core 40 science credits.**

Students learn anatomy and physiology of the human body through a hands-on approach. Using real-world cases, students take the role of a biomedical professional to work together to solve medical mysteries. Hands-on, interactive projects include designing experiments, investigating the function and structures of the human body through dissections, clay modeling, laboratory analysis and using data acquisition software to monitor body functions such as reflex, muscle movement and lung capacities. Students learn to assess and monitor body systems and how they work together.

### T56301 PLTW Medical Interventions (5217)

**Open to grades 11, 12**

**2 semesters, 1 credit per semester**

**Approximate cost per semester: \$52.44**

**Meets requirements: THD, AHD, Core 40**

**Prerequisites: Principles of the Biomedical Sciences, Human Body Systems**

**Dual Credit Available**

**Note: This course counts towards Core 40 science credits.**

Students investigate various medical interventions that extend and improve the quality of life including gene therapy, pharmacology, surgery, prosthetics, rehabilitation and supportive care. The course explores the design and development of various medical interventions such as vascular stents, cochlear implants and prosthetic limbs. In addition, students review the history of organ transplants and gene therapy and stay updated on cutting-edge developments via current scientific literature. Using 3D imaging, data acquisition software and current scientific research, students design a product that can be used as a medical intervention.

### T56401 PLTW Biomedical Innovation (5219)

**Open to grades 12**

**2 semesters, 1 credit per semester**

**Approximate cost per semester: \$52.44**

**Meets requirements: THD, AHD, Core 40**

**Prerequisites: Human Body Systems, or Medical Interventions**

**Dual Credit Available if student has successfully completed the first three courses in the pathway.**

**Note: This course counts towards Core 40 science credits.**

**Note: With approval, qualified PLTW student may use this project for their Senior Project at CEHS and CNHS.**

Biomedical Innovation is the fourth and final Project Lead the Way Biomedical Science course. It is intended to follow the third course, Medical Interventions. In this capstone course students will design and conduct experiments related to the diagnosis, treatment and prevention of disease or illness. They will apply their knowledge and skills to answer questions or to solve problems related to the biomedical sciences. They will work to design an effective emergency room, explore human physiology and design a medical innovation. They will investigate public health issues and forensic autopsy. They may work with a mentor or advisor from a university, hospital, physician's office or industry as they complete

### T56211 Medical Terminology (5274)

**Open to grades 11, 12**

**1 semester, 1 credits per semester**

**Approximate cost per semester: \$99.94**

**Meets requirements: THD, AHD, Core 40**

**Prerequisite(s): Biology**

**Dual Credit Available**

Learn a new language in this one semester elective. Students will learn to define and use medical terminology correctly and will become proficient in pronouncing and spelling medical terms. Students will utilize videos, presentations and hands-on experiences to enhance learning. This course will provide a solid foundation in medical terminology for any student considering a career in health science.

### T56612 Dental Careers I (5203)

**Open to grades 10, 11, 12**

**2 semesters, 2 credits per semester**

**Approximate cost per semester: \$182.33**

**Meets requirements: THD, AHD, Core 40**

**Recommendation(s): PLTW Principles of the Biomedical Sciences, PLTW Human Body Systems**

**Dual Credit Available**

Dental Careers I prepares the student for an entry level dental assisting position. Emphasis is placed on the clinical environment, chair-side assisting, equipment/instrument identification, tray set-ups, sterilization, and characteristics of microorganisms and disease control. In addition, oral, head and neck anatomy, basic embryology, histology, tooth morphology, charting dental surfaces, and illness are all introduced. Simulated in-school laboratories are included to provide opportunities for students to further develop clinical skills and the appropriate ethical behavior.

### T56622 Dental Careers II (5204)

**Open to grades 11, 12**

**2 semesters, 2 credits per semester**

**Approximate cost per semester: \$68.70**

**Meets requirements: THD, AHD, Core 40**

**Prerequisite(s): T56612 Dental Careers I**

This course provides the student with more extensive training as a Dental Assistant. There is excellent opportunity for employment/experience toward college/technical training. The student will perform procedures in our simulated lab such as placing orthodontic wires and preparing tray set-ups for periodontal, endodontic and surgical procedures. The first nine weeks is spent in classroom and simulated laboratory training. Clinical (on-the-job) training at specialty dental offices (i.e. periodontics, orthodontics, etc.) is provided during school hours the 2nd, 3rd and 4th nine weeks.

**T56712 Health Science Education I : Nursing (5282)****Open to grades 10, 11, 12****2 semesters, 2 credits per semester****Approximate cost per semester: \$78.48****Meets requirements: THD, AHD, Core 40****Recommendation(s): PLTW Principles of the Biomedical Sciences, PLTW Human Body Systems****Dual Credit Available**

This course provides entry level training in nursing assisting and other allied health careers. At the completion of this course, students may receive certification as a Certified Nursing Assistant (C.N.A.) through the Indiana State Department of Health. Student will receive certification in CPR/First Aid/AED for the Professional Rescuer. During the first semester, students learn hands-on skills in the classroom and simulated laboratory. These skills include: infection control measures, patient hygiene, nutrition, vital signs, patient movement, etc. Second semester, students receive clinical (on-the-job) experience in nursing or other allied health careers of the student's choice such as physical therapy, pharmacy, special education, etc. Health Sciences Training – Nursing/Allied Health Year One provides a wide range of entry level healthcare skills that gives students a solid foundation for employment and college/technical education.

**T56722 Health Science Education II : Nursing (5284)****Open to grades 11, 12****2 semesters, 2 credits per semester****Approximate cost per semester: \$44.86****Meets requirements: THD, AHD, Core 40****Prerequisite: Health Science Education II : Nursing**

This course curriculum offers medical office training with an emphasis on employability skills, teamwork, and communication. Students also have an opportunity to advance learning in their chosen field and/or explore a variety of nursing and allied health careers. Students receive clinical (on-the-job) experience closely related to the area of their interest(s). Clinical placement begins early in the school year and continues through the fourth nine weeks. Health Sciences Training Nursing/ Allied Health Year Two offers a wonderful opportunity for students to gain in-depth exposure to their potential health career area as well as providing a solid foundation for employment and college/technical education. Student will receive certification in CPR/First Aid/AED for the Professional Rescuer.

**T56512 Veterinary Careers I (5211)****Open to grades 10, 11, 12****2 semesters, 2 credits per semester****Approximate cost per semester: \$85.82****Meets requirements: THD, AHD, Core 40****Recommendation(s): Animal Science, Adv. Life Science: Animals, PLTW Principles of the Biomedical Sciences, PLTW Human Body Systems**

This course provides entry level training as a Veterinary Assistant for students pursuing careers as Veterinarians, Veterinary Technicians, Veterinary Assistants, or other careers involving animals. The focus of the first semester is classroom and laboratory training. The student will have the opportunity to practice assisting with the physical exam, veterinary nursing care, animal restraint and assisting with surgical procedures. Second semester students have the opportunity to receive clinical (on-the-job) training within the professional community. Placements include veterinary offices, animal shelters, humane societies, groomers and animal behavior and training facilities. Students receive certification in CPR/First Aid/AED for the Professional Rescuer.

**T56522 Veterinary Careers II (5212)****Open to grades 11, 12****2 semesters, 2 credits per semester****Approximate cost per semester: \$46.96****Meets requirements: THD, AHD, Core 40****Prerequisite(s): Veterinary Careers I**

This course provides advanced learning in the veterinary field through a four day per week extended lab experience in a veterinary field. Students can focus on specific career interests such as small or large animal vet medicine, exotic vet medicine, wildlife rehabilitation, shelter animals, or obedience training. This opportunity provides the students with a solid foundation for employment and college or technical education.

**HUMAN SERVICES CLUSTER****T57321 Interpersonal Relationships (5364)****Open to grades 9, 10, 11, 12****1 semester, 1 credit per semester****Approximate cost per semester: \$16.21****Meets requirements: THD, AHD, Core 40**

This course addresses essential knowledge and skills needed for positive and productive relationships in all career areas, community, and family settings. Designed for teens that would like a better understanding of human behavior through knowing themselves as individuals, topics include communication skills, career goals, self-esteem, relationships, values clarification, and conflict resolution. This is one of three (3) classes that may be taken as a group in lieu of Health & Safety.

**T57351 Adult Roles and Responsibilities (5330)****Open to grades 11, 12****1 semester, 1 credit per semester****Approximate cost per semester: \$60.00****Meets requirements: THD, AHD, Core 40**

Adult Roles and Responsibilities is recommended for all students as a career sequence course for students with interest in family and community services, personal and family finance, and similar areas. This course is designed to equip students with knowledge and skills needed to successfully handle the daily living challenges of adult life. Students develop skills to build more meaningful, lasting relationships. They will explore many of the issues that challenge the individual and family in today's society. Students complete projects and class activities that involve consumer decision-making about housing, clothing, nutrition and wellness, transportation and financial management.

**T57361 Intro. to Housing & Interior Design (5350)****Open to grades 9, 10, 11, 12****1 semester, 1 credit per semester****Approximate cost per semester: \$31.50****Meets requirements: THD, AHD, Core 40**

Introduction to Housing and Interior Design is a one semester hands-on course designed for students interested in exploring and learning about interiors and housing styles. Topics include choosing a place to live, study of color, elements of design, furniture arrangement, floor plans, choosing backgrounds-walls, floors, windows, decorating and housing careers. This course is filled with many design and craft type projects.

**T57371 Nutrition and Wellness (5342)****Open to grades 9, 10, 11, 12****1 semester, 1 credit per semester****Approximate cost per semester: \$19.03****Meets requirements: THD, AHD, Core 40**

This is a nutrition class that introduces students to only the basics of food preparation so they can become self-sufficient in accessing healthy and nutritious foods. This class helps students to realize the lifelong benefits of sound nutrition and wellness and helps them plan and cook for healthy living. Topics include impact of nutrition on health; making healthy choices; selection and preparation of nutritious meals and snacks, safety and sanitation of food prep, wellness issues and career paths. Much time is spent developing measurement skills and simple food preparation techniques. This is one of three classes that may be taken as a group in lieu of Health & Safety.

**T57391 Sports Nutrition and Wellness (5340)****Open to grades 9, 10, 11, 12****2 semesters, 1 credit per semester****Approximate cost per semester: \$38.06****Meets requirements: THD, AHD, Core 40**

Sports Nutrition and Wellness is a course which provides an extensive study of nutrition. Sports Nutrition and Wellness is an especially appropriate course for students interested in careers in the medical field, athletic training and dietetics. This course is designed to benefit the nutritional needs for all students, but especially athletes. Topics include: simple food preparation, individual dietary needs, nutrition information and analysis, pre-game and recovery foods/drinks.

**T25502 Advanced Life Science: Foods (5072)****Open to grades 11, 12****2 semesters, 1 credit per semester May include travel period****Approximate cost per semester: \$68.38****Meets requirements: THD, AHD, Core 40, NCAA****Recommendation: Two years of Core 40/AHD Science****Note: This course counts toward Core 40 Science credits.****Note: Qualifies as a Quantitative Reasoning course for the General, Core 40, AHD and THD diplomas.**

Advanced Life Science: Foods is a two-semester course that provides students with opportunities to participate in a variety of activities including laboratory work. This is a standards-based, interdisciplinary science course that integrates biology, chemistry and microbiology in the context of foods and the global food industry. Students formulate, design and carry out food base laboratory and field investigations as an essential course component. Students understand how biology, chemistry and physics principles apply to the composition of foods, the nutrition of foods, food and food product development, food processing, food safety and sanitation, food packaging and food storage. Students apply the principles of scientific inquiry to solve problems related to biology, physics and chemistry. In the context of highly-advanced industry applications of foods.

**T57701 Introduction to Fashion and Textiles (5380)****Open to grades 9, 10, 11, 12****1 or 2 semesters, 1 credit per semester****Approximate cost per semester: \$21.78****Meets requirements of: THD, AHD, Core 40**

This is an introductory course for students interested in academic enrichment or a career in the fashion, textile, and apparel industry. This course addresses knowledge and skills related to design, production, acquisition, and distribution in the fashion, textile, and apparel arena. It includes the study of personal, academic, and career success; careers in the fashion, textile, and apparel industry; factors influencing the merchandising and selection of fashion, textile, and apparel goods and their properties, design, and production; and consumer skills. A project-based approach integrates instruction and laboratory experiences including application of the elements and principles of design; selection, production, alteration, repair, and maintenance of apparel and textile products; product research, development, and testing; and application of technical tools and equipment utilized in the industry.

**T57331 Child Development/Adv. Child Dev. (5362)****Open to grades 9, 10, 11, 12****2 semesters, 1 credit per semester****Approximate cost per semester: \$36.18 Sem. 1 / \$20.09/Sem. 2****Meets requirements: THD, AHD, Core 40**

Semester one students experience an introductory course especially relevant for students interested in careers that draw on knowledge of children, child development, and nurturing of children. It includes the study of prenatal development and birth; growth and development of children; child care giving and nurturing; and support systems for parents and caregivers. Semester two includes the study of professional and ethical issues in child development; child growth and development; child development theories, research, and best practices; child health and wellness; special conditions affecting children; and career exploration in child development and nurturing. This is one of three (3) classes that may be taken as a group in lieu of Health & Safety. Students participate in an in-school lab gaining experience with young children through participation and observation. The emphasis is on parent/child activities.

**T57102 Early Childhood Education I (2 hour) (5412)****T57103 Early Childhood Education I (3 hour) (5412)****Open to grades 11, 12****2 semesters, 2/3 credits per semester****Approximate cost per semester: \$55.92****Meets requirements: THD, AHD, Core 40****Prerequisite: Child Development****Dual Credit Available**

Early Childhood Education 1 prepares students for employment in early childhood education and related careers that involve working with children from birth to 8 years (3rd grade) and provides the

foundations for study in higher education that leads to early childhood education and other child-related careers. Major course topics include: career paths in early childhood education; promoting child development and learning; building family and community relationships; observing, documenting, and assessing to support young children and families; using developmentally effective approaches; using content knowledge to build meaningful curriculum, and becoming an early childhood education professional. The course addresses planning and guiding developmentally appropriate activities for young children in various childcare settings; developmentally appropriate practices of guidance and discipline; application of basic health, safety, and nutrition principles when working with children. Intensive experiences in one or more early childhood settings, resumes, and career portfolios are required components. High school students while under the supervision of the instructor will lead a preschool for children ages 3 – 4 years during the first semester of the class. Students will be placed in community early childhood centers during the second semester.

**T57112 Early Childhood Education II (2 hr. Option) (5406)****T57113 Early Childhood Education II (3 hr. option) (5406)****Open to grades 12****2 semesters, 2/3 credits per semester****Approximate cost per semester: \$55.92****Meets requirements: THD, AHD, Core 40****Prerequisite: Early Childhood Education 1****Dual Credit Available**

ECE 2 is a sequential course that builds on the foundational knowledge and skills of Early Childhood Education I, which is a required prerequisite. In ECE 2 students further refine, develop. The course standards parallel the expectations and documentation required for Child Development Associate (CDA) credentialing. Extensive experiences in one or more early childhood education settings are required: a minimum total of 480 hours must be accrued in ECE I and ECE II. These experiences may be either school-based or "on-the-job" in community-based early childhood education centers, or in a combination of the two.

**T57122 Education Professions I (2 hour) (5408)****T57123 Education Professions I (3 hour) (5408)****Open to grades 11, 12****2 semesters, 2/3 credits per semester****Approximate cost per semester: \$38.90****Meets requirements: THD, AHD, Core 40****Recommendation(s): Child Development/Adv. Child Development****Dual Credit Available**

This is an exciting hands-on exploration of learning and teaching that prepares students for employment in education and related careers and provides the foundation for study in higher education. An active learning approach incorporates communication, leadership and management skills into the study of education and related careers. The course of study includes, but is not limited to: the teaching profession, the learner and the learning process, planning instruction, learning environment, and instructional and assessment strategies. Exploratory field experiences in classroom settings and career portfolios are required components. A standards-based plan guides the students' field experiences. Students are monitored in their field experiences by the Education Professions teacher. Students should be motivated toward exploring a career in education or related careers, have a good attendance record and be willing to accept numerous responsibilities while interning in an elementary or middle school classroom. Students who enjoy working with children will love the activities and experiences in this class. Articulation with postsecondary programs is encouraged.

**T57132 Education Professions II (2 hour) (5404)****T57133 Education Professions II (3 hour) (5404)****Open to grades 12****2 semesters, 2/3 credits per semester****Approximate cost per semester: \$38.90****Meets requirements: THD, AHD, Core 40****Prerequisite(s): Education Professions I**

Designed for returning Teacher Education students, this course is a continuation of Education Professions 1. The course prepares students

for employment in education and related careers and provides the foundation for study in higher education in these career areas. An active learning approach incorporates communication, leadership and management skills into the study of education and related careers. The course of study includes, but is not limited to: the teaching profession, the learner and the learning process, planning instruction, learning environment, and instructional and assessment strategies. Extensive field experiences in one or more classroom settings, resumes, and career portfolios are required components. Students are monitored in their field experiences by the Education Professions 2 teacher. Articulation with postsecondary programs is encouraged.

### **T57504 Cosmetology I (5802)**

**Open to grades 11, 12**

**2 semesters, 4 credits per sem. at McDowell (3 periods) + Extra Clock Time**

**Approximate cost per semester: \$524.95**

**Meets requirements: THD, AHD, Core 40**

**Recommendation(s): Interpersonal Relationships**

**Prerequisite(s): Application and/or interview may be required.**

**Dual Credit Available**

Cosmetology 1 offers an introduction to cosmetology with emphasis on basic practical skills and theories including roller control, quick styling, shampooing, hair coloring, permanent waving, facials, manicuring business and personal ethics, and bacteriology and sanitation. In the second semester greater emphasis is placed on the application and development of these skills. State of Indiana requires a total of 1500 hours of instruction for licensure. This class is in session until 5:30 p.m.

### **T57514 Cosmetology II (5806)**

**Open to grades 12**

**2 semesters, 4 credits per sem. at McDowell (3 periods) + Extra Clock Time**

**Approximate cost per semester: \$22.00**

**Meets requirements: THD, AHD, Core 40**

**Prerequisite(s): Cosmetology I**

**Dual Credit Available**

Cosmetology II emphasis will cover the development of advanced skills in styling, hair coloring, permanent waving, facials and manicuring. Students will also study anatomy and physiology, professionalism, and salon management in relation to cosmetology. This class is in session until 5:30 p.m.

### **T57210 Intro to Culinary Arts & Hospitality Management (5438)**

**Open to grades 9, 10, 11, 12**

**2 semesters, 1 credit per semester**

**Approximate cost per semester: \$36.82**

**Meets requirements: THD, AHD, Core 40**

This course is recommended for all students regardless of their career cluster or pathway in order to build basic culinary arts knowledge and skills. It is especially appropriate for students with an interest in careers related to Hospitality, Tourism, and Culinary Arts. A project-based approach that utilizes higher order thinking, communication, leadership, and management processes is recommended. Topics include basic culinary skills in the foodservice industry, safety and sanitation, nutrition, customer relations and career investigation. Students explore this industry and examine their own career goals in light of their findings. Laboratory experiences that emphasize industry practices and develop basic skills are required components of this course.

### **T57212 Culinary Arts & Hospitality I I (2 hr.) (5440)**

### **T57213 Culinary Arts & Hospitality I I (3 hr.) (5440)**

**Open to grades 10, 11, 12**

**2 semesters, 2/3 credits per semester**

**Approximate cost per semester: \$101.35**

**Meets requirements: THD, AHD, Core 40**

**Recommendation: Introduction to Culinary Arts & Hospitality**

This course prepares students for occupations and higher education programs of study related to the entire spectrum of careers in the hospitality industry. It prepares students to enter the Advanced Culinary Arts or Advanced Hospitality courses. Major topics include: introduction to the hospitality industry; food safety and personal hygiene; sanitation and safety; regulations, procedures, and emergencies; basic culinary skills; culinary math; food preparation techniques and applications; principles of purchasing, storage, preparation, and service of food and food products; application of

sanitation and safety principles to maintain safe and healthy food service and hospitality environments; use and maintenance of related tools and equipment; and application of management principles. Intensive, teacher-monitored standards-based laboratory experiences with commercial applications are required.

### **T57222 Culinary Arts & Hospitality II: Culinary Arts (2 hr) (5346)**

### **T57223 Culinary Arts & Hospitality II: Culinary Arts (3 hr) (5346)**

**Open to grades 11, 12**

**2 semesters, 2/3 credits per semester**

**Approximate cost per semester: \$83.86**

**Meets requirements: THD, AHD, Core 40**

**Prerequisite(s): Culinary Arts and Hospitality I**

**Dual Credit Available**

Advanced Culinary Arts prepares students for occupations and higher education programs of study related to the entire spectrum of careers in the food industry, including (but not limited to) food production and services; food science, dietetics, and nutrition; and baking and pastry arts. Major topics for this advanced course include: basic baking theory and skills, introduction to breads, introduction to pastry arts, nutrition, nutrition accommodations and adaptations, cost control and purchasing, and current marketing and trends. Instruction and intensive laboratory experiences include commercial applications of principles of nutrition, aesthetic, and sanitary selection; purchasing, storage, preparation, and service of food and food products; using and maintaining related tools and equipment; baking and pastry arts skills; managing operations in food service, food science, or hospitality establishments; providing for the dietary needs of persons with special requirements; and related research, development, and testing. Intensive laboratory experiences with commercial applications are a required component of this course of study. Student laboratory experiences may be either school-based or "on-the-job" or a combination of the two.

### **T57233 Culinary Arts and Hospitality II: Hospitality Management (3 hour) (5458)**

**Open to grades 12**

**2 semesters, 3 credits per semester**

**Approximate cost per semester: \$39.60**

**Meets requirements: THD, AHD, Core 40**

**Prerequisite(s): Culinary Arts and Hospitality II: Culinary Arts**

Advanced Hospitality Management prepares students for employment in the hospitality industry. It provides the foundations for study in higher education that leads to a full spectrum of hospitality careers. This is a broad-based course that introduces students to all segments of hospitality, what it includes, and career opportunities that are available; provides a survey of management functions, highlighting basic theories and facts; and exposes students to current trends and current events within the industry. Three major goals of this course are for students to be able to: Identify current trends in hotel and restaurant management, distinguish the difference between hospitality and tourism, and state differences in front of the house versus back of the house. Intensive experiences in one or more hospitality industry settings are a required component of the course.

## **PROTECTIVE SERVICES CLUSTER**

### **T57012 Criminal Justice I (5822)**

**Open to grades 11, 12**

**2 semesters, 2 credits per semester**

**Approximate cost per semester: \$92.72**

**Meets requirements: THD, AHD, Core 40**

**Recommendation(s): Digital App. & Responsibility, Interpersonal Relationships**

**Dual Credit Available**

Criminal Justice I Introduces specialized classroom and practical experiences related to public safety occupations such as law enforcement, loss prevention services, and homeland security. This course provides an introduction to the purposes, functions, and history of the three primary parts of the criminal justice system as well as an introduction to the investigative process. Oral and written communication skills should be reinforced through activities that model public relations and crime prevention efforts as well as the preparation of police reports. This course provides the opportunity for

dual credit for students who meet postsecondary requirements for earning dual credit and successfully complete the dual credit requirements of this course.

### **T57022 Criminal Justice II Advanced (5824)**

**Open to grades 12**

**2 semesters, 2 credits per semester**

**Approximate cost per semester: \$76.26**

**Meets requirements: THD, AHD, Core 40**

**Prerequisite(s): Criminal Justice I**

**Dual Credit Available**

Criminal Justice II introduces students to concepts and practices in controlling traffic as well as forensic investigation at crime scenes. Students will have opportunities to use mathematical skills in crash reconstruction and analysis activities requiring measurements and performance of speed/acceleration calculations. Additional activities simulating criminal investigations will be used to teach scientific knowledge related to anatomy, biology, and chemistry as well as collection of evidence and search for witnesses, developing and questioning suspects, and protecting the integrity of physical evidence found at the scene and while in transit to a forensic science laboratory. Procedures for the use and control of informants, inquiries keyed to basic leads, and other information-gathering activity and chain of custody procedures will also be reviewed.

## **TRANSPORTATION CLUSTER**

### **T55031 Introduction to Transportation (4798)**

**Open to grades 9, 10, 11, 12**

**2 semesters, 1 credits per semester**

**Approximate cost per semester: \$10.00**

**Meets requirements: THD, AHD, Core 40**

This is an introductory course designed to help students become familiar with fundamental principles in modes of land, sea, air, and space transportation, including basic mechanical skills and processes involved in transportation of people, cargo and goods. Students gain and apply knowledge and skills in the safe application, design, production, and assessment of products, services, and systems as it relates to the transportation industries. Content of this course includes the study of how transportation impacts individuals, society, and the environment. This course allows students to reinforce, apply, and transfer their academic knowledge and skills to a variety of interesting and relevant transportation related activities, problems, and settings.

### **T58012 Automotive Services Technology I (5510)**

**Open to grades 10, 11, 12**

**2 semesters, 2 credits per semester**

**Approximate cost per semester: \$73.60**

**Meets requirements: THD, AHD, Core 40**

**Recommendation(s): Introduction to Transportation**

**Dual Credit Available**

This is a one-year course that encompasses the sub topics of the NATEF/ ASE identified areas of Steering & Suspension and Electrical Systems. This one-year course offering may be structured in a series of two topics per year offered in any combination of instructional strategies of semester based or yearlong instruction. Additional areas of manual transmissions and differentials, automatic transmissions, air conditioning, and engine repair should be covered as time permits. This one-year offering must meet the NATEF program certifications for the two primary areas offered in this course. This course provides the opportunity for dual credit for students who meet postsecondary requirements for earning dual credit and successfully complete the dual credit requirements of this course. Mathematical skills will be reinforced through precision measuring activities and cost estimation/calculation activities. Scientific principles taught and reinforced in this course include the study of viscosity, friction, thermal expansion, and compound solutions. Written and oral skills will also be emphasized to help students communicate with customers, colleagues, and supervisors.

### **T58022 Automotive Services Technology II (5546)**

**Open to grades 11, 12**

**2 semesters, 2 credits per semester**

**Approximate cost per semester: \$73.60**

**Meets requirements of: THD, AHD, Core 40**

**Prerequisite: T58012 Automotive Services Technology I**

**Dual Credit Available**

Automotive Services Technology 2 is a one-year course that encompasses the sub topics of the NATEF/ASE identified areas of Braking Systems and Engine Performance. This one-year course offering may be structured in a series of two topics per year offered in any combination of instructional strategies of semester based or year-long instruction. Additional areas of manual transmissions /differentials, automatic transmissions, air conditioning, and engine repair should be covered as time permits. This one-year offering must meet the NATEF program certifications for the two primary areas offered in this course. Mathematical skills will be reinforced through precision measuring activities and cost estimation/calculation activities. Scientific principles taught and reinforced in this course include the study of viscosity, friction, thermal expansion, and compound solutions. Written and oral skills will also be emphasized to help students communicate with customers, colleagues, and supervisors.

### **T58032 Automotive Services Technology III (5546)**

**Open to grade 12**

**2 semesters, 2 credits per semester**

**Approximate cost per semester: \$73.60**

**Meets requirements: THD, AHD, Core 40**

**Prerequisite: Automotive Services Technology II with a "C" or better**

This program is designed for third-year Automotive Technology students. Students must have met the program standards and maintained a grade of C or above in Year One and Year Two Auto Technology classes before they can be placed in a Community Training Site/Automotive Position.

## **WORK-BASED LEARNING**

### **C4 Work-Based Learning (WBL) Options**

Components of the WBL system involve cooperative education, extended labs and advanced placements in partnership with community learning stations through C4 programming. Additional WBL opportunities available to all students include job shadowing, internship and on-the-job training.

**Advanced Job Placement (AJP):** Advanced occupational training students may qualify for community placement training if they meet the criteria for eligibility. To qualify, the student must be a high school senior and the C4 instructor must agree that the student has shown the necessary technical skills to work in the community. The students must also be in good standing for graduation, have a good behavioral transcript, show no attendance issues, meet the standards for placement and have passed the End-of-Program Assessment. Representatives from local industry will interview students prior to placement. Selected students are placed in on-the-job training sites under the supervision of a department manager. Student will work a minimum of 15 hours a week.

**Co-op:** The expectation for co-op students is that they will be placed into employment opportunities within the community for pay.

**Extended Lab:** Students in extended labs engage in community placement sometime after the first nine weeks. This experience is an extension of their classroom training; placement sites provide training and evaluation. Due to occupational training requirement, there is no pay for this experience.

**T59579 Interdisciplinary Coop. Education (ICE) Related (5902)****Open to grade 12****2 semesters, 1 credit per semester****T59599 Interdisciplinary Coop. Education (ICE) Job (5902)****Open to grade 12****2 semesters, 2 credits per semester****Approximate cost per semester: \$45.16****Meets requirements: THD, AHD, Core 40****Prerequisite(s): Application and coordinator approval required.****Student must provide their own transportation. Minimum age of 16 and eligibility requirements of the Federal and State Child Labor Laws.**

This course provides occupational training in work areas not currently provided for in regular Career and Technical Education courses. It combines classroom instruction and work experiences in community workstations. In addition to a morning schedule of required and elective courses, the student attends a related class each day before being released to work in the community. In the related class, students study topics relevant to employee effectiveness and making the transition into the workforce. Work sites are identified through a cooperative effort of the student and teacher, who will supervise the total program. Students are required to provide their own transportation.

# SPECIAL EDUCATION

The majority of students who receive special education services at Columbus North High School receive their instruction in general education classes during most of the school day. Therefore, most course selection offerings will be listed in other areas of this course catalog. The Case Conference Committee may decide that the individual needs of a special education student may include some instruction in a special educational classroom. These special offerings are listed below.

**85031/85033 Guided Resource****Open to grades 9, 10, 11, 12****Non-credit Approximate cost: None****Prerequisite(s): Recommendation from Special Education teacher**

Guided Resource assists students with assignments from their general education classes. Students are tutored in various subjects, and accommodations for course-work are made in order to meet individual student needs.

**83101 Basic Skills: Developmental Math****Open to grades 9,10,11,12****2 semesters, 1 credit per sem****Approximate cost: None****Prerequisite(s): Recommendation from Special Education teacher****Note: This course does not qualify for Mathematics credit requirements or for the attainment of a high school diploma.**

Developmental Math is a math remediation class for students who still struggle with math basics. The focus of the class is to learn basic math skills. Students will be exposed to daily connections that make math meaningful by relating it to the real world. The intent of this class is for students to develop math independence and will learn to take ownership of their own learning and improvement.

**83001 Basic Skills: Developmental Reading****Open to grades 9,10,11,12****2 semesters, 1 credit per sem****Approximate cost: None****Prerequisite(s): Recommendation from Special Education teacher****Note: This course does not qualify for English credit requirements or for the attainment of a high school diploma.**

Developmental Reading is designed for students who are reading substantially below grade level. The intent of this class is for students to master the fundamentals of reading. The program involves intense reading training. Students will make their reading meaningful by discussing it within the parameters of real world situations. Students will strive to develop reading independence and to take ownership of their own learning and their improvement in all areas through their reading.

**SPECIAL EDUCATION LIFE SKILLS**

The Life Skills Class at North High School is designed for students who require a curriculum that teaches daily living as well as academic skills. The curriculum focuses on functional academics, vocational skills, and daily living skills. Students work toward their individual goals to become more productive, independent employees as well as lifelong members of the community. (Life Skills does not meet high school diploma requirements.)

**84601 Basic Skills: Career Exploration****Open to grades 9, 10, 11, 12****2 semesters, 1 credit per semester****Approximate cost: None****Prerequisite(s): Recommendation from Special Education teacher****Note: This course does not qualify for high school credit requirements or for the attainment of a high school diploma.**

This course extends the Career Exploration Program for the students in Life skills program. The course focuses on continuing and reinforcing reading fundamentals and application to career skills development. Further connections to real life applications will be utilized, including a job shadowing opportunity.

**84011 Reading (Technical Skills)****Open to grades 9, 10, 11, 12****2 semesters, 1 credit per semester****Approximate cost: None****Prerequisite(s): Recommendation from Special Education teacher****Note: This course does not qualify for English credit requirements or for the attainment of a high school diploma.**

This course is focused on teaching students how to use reading functionally in everyday situations. The course curriculum is based upon teaching students to independently use a strong sight-word vocabulary that can be used in a variety of settings such as work, the community, and social environments. Students will practice reading street and safety signs as well as reading menus, order forms, and labels to gain a larger vocabulary.

**84101 Math (Technical Skills)****Open to grades 9, 10, 11, 12****2 semesters, 1 credit per semester****Approximate cost: None****Prerequisite(s): Recommendation from Special Education teacher****Note: This course does not qualify for Mathematics credit requirements or for the attainment of a high school diploma.**

This course is designed to teach students mathematical skills they will use in daily situations. The curriculum focuses on money recognition, counting, and usage. It also focuses on balancing a checkbook and savings account, as well as addition and subtraction skills that will be used when making purchases at a store.

**84201 Health & Wellness (Technical Skills)****Open to grades 9,10,11,12****2 semesters, 1 credit per semester****Approximate cost: None****Prerequisite(s): Recommendation from Special Education teacher****Note: This course does not qualify for Health credit requirements or for the attainment of a high school diploma.**

Health & Wellness is designed to teach students health & wellness skills they use in daily situations. The curriculum focuses on personal health, nutrition, and personal hygiene. It also focuses on physical fitness, as well as disease prevention skills that will be used in daily living.



**84901 Life Skills Self-Determination: Independent Living Skills**

**Open to grades 9, 10, 11, 12**

**2 semesters, 1 credit per semester**

**Approximate cost: None**

**Prerequisite(s): Recommendation from Special Education teacher**

**Note: This course does not qualify for high school credit requirements or for the attainment of a high school diploma.**

Life Skills Independent Living Skills is designed to provide students with a variety of skills that will make them more independent and productive members of their community. Students participate in weekly community outings where they learn to eat at restaurants, shop at grocery stores, buy clothes, and provide themselves with other necessities. Students will also participate in a variety of social activities that will assist them with learning how to access these activities in their own community.

**84501 Vocational Skills**

**Open to grades 9, 10, 11, 12**

**2 semesters, 1 credit per semester**

**Approximate cost: None**

**Prerequisite(s): Recommendation from Special Education teacher**

**Note: This course does not qualify for high school credit requirements or for the attainment of a high school diploma.**

Vocational Skills is designed to teach students skills that make them more employable. Students participate in a volunteer job site program that allows them to leave the North campus to work at specific jobs. The curriculum also involves filling out applications, learning about paychecks, and learning effective strategies to use when working with others.